



# PhysicsByAaryan

## TIFR Physics 2019

Complete TIFR GS Physics Paper · 2019 · 55 questions  
Visit: [physicsbyaaryan.com](http://physicsbyaaryan.com) · [physicspyq.com](http://physicspyq.com)

### Classical Mechanics

#### Q1. [TIFR\_2019\_A\_Q6]

Year 2019 · Classical Mechanics · Basic Mechanics · Both int. phd and phd · 3 marks

TIFR GS	2019	Section A
---------	------	-----------

A particle of mass  $m$  is placed on an inclined plane making an adjustable angle  $\theta$  with the horizontal, as shown in the figure. The coefficient of friction between the particle and the inclined plane is  $\mu$ . If the inclined plane is moving horizontally with a uniform acceleration  $a < g/\mu$  (see figure), the value of  $\theta$  for which the particle will remain at rest on the plane is

- (a)  $\theta = \tan^{-1} \left( \frac{\mu g + a}{g + \mu a} \right)$
- (b)  $\theta = -\cot^{-1} \left( \frac{\mu a + g}{a + \mu g} \right)$
- (c)  $\theta = \tan^{-1} \left( \frac{\mu g + a}{g - \mu a} \right)$
- (d)  $\theta = \cot^{-1} \left( \frac{\mu a - g}{a + \mu g} \right)$

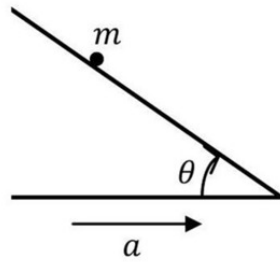

**Q2. [TIFR\_2019\_A\_Q7]**

Year 2019 · Classical Mechanics · Oscillations · Both int. phd and phd · 3 marks

TIFR GS	2019	Section A
---------	------	-----------

Two bodies A and B of equal mass are suspended from two rigid supports by separate massless springs having spring constants  $k_1$  and  $k_2$  respectively. If the bodies oscillate vertically such that their maximum velocities are equal, the ratio of the amplitude of oscillations of A to that of B is

- (a)  $k_1/k_2$   
 (b)  $k_2/k_1$   
 (c)  $\sqrt{k_1/k_2}$   
 (d)  $\sqrt{k_2/k_1}$

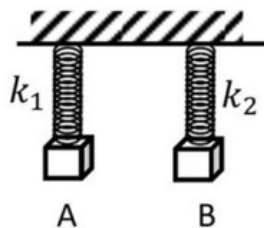
**Q3. [TIFR\_2019\_A\_Q8]**

Year 2019 · Classical Mechanics · Basic Mechanics · Both int. phd and phd · 3 marks

TIFR GS	2019	Section A
---------	------	-----------

A particle of mass  $m$  is bounced on the ground with a velocity  $u$  making an angle of  $\theta$  with the ground. The coefficient of restitution for collisions between the particle and the ground is  $\epsilon$  and frictional effects are negligible both on the ground and in the air. The horizontal distance travelled by the particle from the point of initial impact till it begins to slide along the ground is

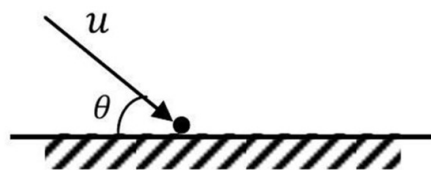

- (a)  $\frac{u^2}{2g} \left( \frac{\epsilon}{1-\epsilon} \right) \sin 2\theta$   
 (b)  $\frac{u^2}{g} \left( \frac{1}{1-\epsilon} \right) \sin \theta$   
 (c)  $\frac{u^2}{g} \left( \frac{\epsilon}{1-\epsilon} \right) \tan 2\theta$   
 (d)  $\frac{u^2}{g} \left( \frac{\epsilon}{1-\epsilon} \right) \sin 2\theta$

**Q4. [TIFR\_2019\_A\_Q9]**

Year 2019 · Classical Mechanics · Rotational Motion · Both int. phd and phd · 3 marks

TIFR GS	2019	Section A
---------	------	-----------

The three-dimensional object sketched on the right is made by taking a solid sphere of uniform density (shaded) with radius  $R$ , and scooping out a spherical cavity (unshaded) as shown, which has diameter  $R$ . If this object has mass  $M$ , its moment of inertia about the tangential axis passing through the point where the spheres touch (as shown in the figure) is

- (a)  $\frac{3}{16} MR^2$
- (b)  $\frac{62}{35} MR^2$
- (c)  $\frac{31}{70} MR^2$
- (d)  $\frac{31}{20} MR^2$

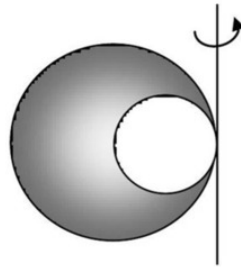

**Q5. [TIFR\_2019\_B\_Q3]**

Year 2019 · Classical Mechanics · Lagrangian and Hamiltonian · Only int. Phd · 5 marks

TIFR GS	2019	Section B
---------	------	-----------

A pendulum is created by hanging a heavy bob of mass  $m$  from a rigid support (taken as zero level of potential) symmetrically using two massless inextensible strings, each of length  $\ell$ , making an equilateral triangle as shown in the figure below.

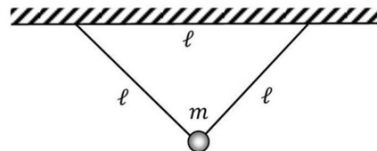

A correct Lagrangian for the angular oscillations of the bob in the plane perpendicular to the paper is

- (a)  $L = \frac{3}{8} m \ell^2 \dot{\theta}^2 - \sqrt{3} m g \ell \sin^2 \frac{\theta}{2}$
- (b)  $L = \sqrt{3} m \ell^2 \dot{\theta}^2 + 4 m g \ell \sin^2 \frac{\theta}{2}$
- (c)  $L = \frac{3}{4} m \dot{\theta}^2 - \sqrt{3} \frac{m g}{\ell} \sin^2 \frac{\theta}{2}$
- (d)  $L = \frac{3}{8} m \ell^2 \dot{\theta}^2 + m g \ell \dot{\theta} \sec^2 \theta + \sqrt{3} m g \ell \sin^2 \frac{\theta}{2}$

**Q6. [TIFR\_2019\_B\_Q4]**

Year 2019 · Classical Mechanics · Oscillations · Only int. Phd · 5 marks

TIFR GS	2019	Section B
---------	------	-----------

A perfectly straight tunnel is dug between any two points on the surface of the Earth, which can be treated as a static sphere of uniform density  $\rho$ . The tunnel does not necessarily pass through the centre of the Earth. If a particle is allowed to slide without friction in this tunnel under the action of the Earth's gravity, it will execute simple harmonic motion with time period

- (a)  $\sqrt{3/2\rho G}$
- (b)  $\sqrt{3/2\pi\rho G}$
- (c)  $\sqrt{6\pi/\rho G}$
- (d)  $\sqrt{3\pi/\rho G}$

**Q7. [TIFR\_2019\_B\_Q5]**

Year 2019 · Classical Mechanics · Special Theory of Relativity · Only int. Phd · 5 marks

TIFR GS	2019	Section B
---------	------	-----------

In a futuristic experiment, two rocket ships, each containing one astronaut Rakesh and Sunita respectively, blasted off from the Earth's surface simultaneously, and travelled into space in straight lines in opposite directions at uniform speeds of  $0.3c$  and  $0.5c$  respectively. They both travelled in straight lines for some time, then reversed direction smoothly and returned along the same paths with the same speeds. It was found that they returned simultaneously after exactly 9.0 years. Which of the following statements is correct?

- (a) The age of Rakesh increased by about 8.6 years and that of Sunita by about 7.8 years.
- (b) The ages of both Rakesh and Sunita increased by about 3.06 years.
- (c) The age of Rakesh increased by about 9.4 years and that of Sunita by about 10.4 years.
- (d) The ages of both Rakesh and Sunita increased by 9.0 years.

**Q8. [TIFR\_2019\_C\_Q3]**

Year 2019 · Classical Mechanics · Lagrangian and Hamiltonian · Only PhD · 5 marks

TIFR GS	2019	Section C
---------	------	-----------

A bead of mass  $m$  slides under the influence of gravity along the frictionless interior of a hemispherical cup of radius  $a$  sunk vertically into the ground with its open side level with the ground (see sketch on the right).

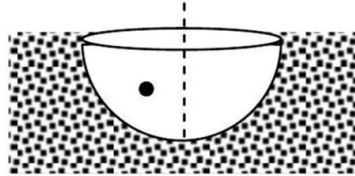

In terms of spherical polar coordinates  $(\theta, \varphi)$  set up with the centre of the upper circle as origin, the Hamiltonian  $H$  for this system will be

- (a)  $H = \frac{m}{2} (a^2 \dot{\theta}^2 + a^2 \dot{\varphi}^2 \csc^2 \theta) + 2mg a \sin^2 \frac{\theta}{2}$   
 (b)  $H = \frac{m}{2} (a^2 \dot{\theta}^2 + a^2 \dot{\varphi}^2 \sin^2 \theta) + 2mg a \sin^2 \frac{\theta}{2}$   
 (c)  $H = \frac{1}{2ma^2} (p_\theta^2 + p_\varphi^2 \sin^2 \theta) + 2mg a \sin^2 \frac{\theta}{2}$   
 (d)  $H = \frac{1}{2ma^2} (p_\theta^2 + p_\varphi^2 \csc^2 \theta) + 2mg a \sin^2 \frac{\theta}{2}$

**Q9. [TIFR\_2019\_C\_Q4]**

Year 2019 · Classical Mechanics · Special Theory of Relativity · Only PhD · 5 marks

TIFR GS	2019	Section C
---------	------	-----------

On a compact stellar object the gravity is so strong that a body falling from rest will soon acquire a velocity comparable with that of light. If the force on this body is  $F = mg$  where  $m$  is the relativistic mass and  $g$  is a constant, the velocity of this falling body will vary with time as

- (a)  $v = \frac{c}{1 - \frac{2c}{gt}}$   
 (b)  $v = c \tanh \frac{gt}{c}$   
 (c)  $v = \frac{2c}{\pi} \tan \frac{gt}{c}$   
 (d)  $v = c \left\{ 1 - \exp \left( -\frac{gt}{c} \right) \right\}$

**Electromagnetism**

**Q10.** [TIFR\_2019\_A\_Q10]

Year 2019 · Electromagnetism · Magnetostatics · Both int. phd and phd · 3 marks

TIFR GS	2019	Section A
---------	------	-----------

Consider three straight, coplanar, parallel wires of infinite length where the distance between adjacent wires is  $d$ . Each wire carries a current  $I$  in the same direction. The perpendicular distance from the middle wire (on either side) where the magnetic field vanishes is

- (a)  $d/\sqrt{3}$
- (b)  $2d/3$
- (c)  $d/3$
- (d)  $2d/\sqrt{3}$

**Q11.** [TIFR\_2019\_A\_Q11]

Year 2019 · Electromagnetism · Electric Field in matter · Both int. phd and phd · 3 marks

TIFR GS	2019	Section A
---------	------	-----------

A point charge  $q < 0$  is brought in front of a grounded conducting sphere. If the induced charge density on the sphere is plotted such that the thickness of the black shading is proportional to the charge density, the correct plot will most closely resemble

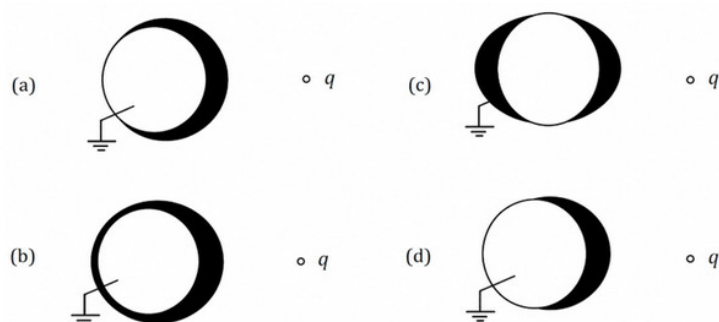

**Q12.** [TIFR\_2019\_A\_Q12]

Year 2019 · Electromagnetism · Electrodynamics · Both int. phd and phd · 3 marks

TIFR GS	2019	Section A
---------	------	-----------

A circular coil of conducting wire, of radius  $a$  and  $n$  turns, is placed in a uniform magnetic field  $\vec{B}$  along the axis of the coil and is then made to undergo simple harmonic oscillations along the direction of the axis. The current through the coil will be best described by

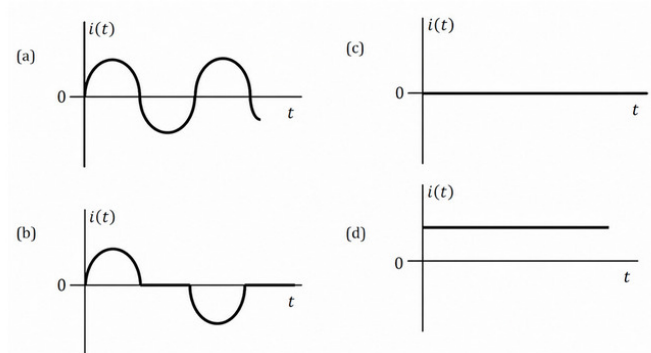

**Q13.** [TIFR\_2019\_A\_Q13]

Year 2019 · Electromagnetism · EM Waves · Both int. phd and phd · 3 marks

TIFR GS	2019	Section A
---------	------	-----------

A plane electromagnetic wave travelling through vacuum has electric field  $\vec{E}$  and magnetic field  $\vec{B}$  defined as

$$\begin{aligned} \vec{E} &= (\hat{i} + \hat{j})E_0 \exp i(\omega t - \vec{k} \cdot \vec{x}) \\ \vec{B} &= (\hat{i} - \hat{j} - \hat{k})B_0 \exp i(\omega t - \vec{k} \cdot \vec{x}) \end{aligned}$$

where  $E_0$  and  $B_0$  are real constants. The time-averaged Poynting vector will be given by

(a)  $\vec{S} = -\frac{2}{\sqrt{\epsilon_0 \mu_0}} E_0 B_0 (\hat{i} - \hat{j} + 2\hat{k})$

(b)  $\vec{S} = -\frac{1}{2} \sqrt{\frac{3\epsilon_0}{\mu_0}} E_0^2 (\hat{i} - \hat{j} + 2\hat{k})$

(c)  $\vec{S} = \sqrt{\frac{\epsilon_0}{6\mu_0}} E_0^2 (-\hat{i} + \hat{j} - 2\hat{k})$

(d)  $\vec{S} = \frac{1}{2} \sqrt{\frac{\epsilon_0}{\mu_0}} B_0^2 (\hat{i} - \hat{j} + 2\hat{k})$

**Q14.** [TIFR\_2019\_B\_Q15]

Year 2019 · Electromagnetism · Electrostatics · Only int. Phd · 5 marks

TIFR GS	2019	Section B
---------	------	-----------

The electric charge density  $\rho(r)$  inside a heavy spherical nucleus as a function of distance  $r$  from the centre may be approximated most closely by

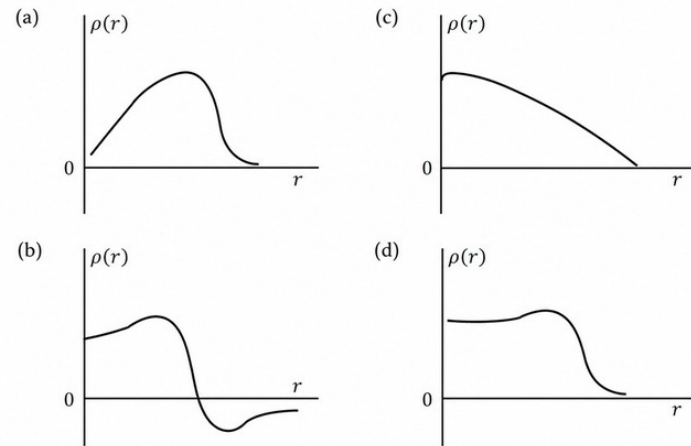

**Q15.** [TIFR\_2019\_B\_Q6]

Year 2019 · Electromagnetism · Magnetostatics · Only int. Phd · 5 marks

TIFR GS	2019	Section B
---------	------	-----------

Consider a hydrogenic atom in its ground state as conceived in Bohr's theory, where an electron of charge  $-e$  is rotating about a central nucleus of charge  $+Ze$  in a circular orbit of radius  $a = 4\pi\epsilon_0\hbar^2/Ze^2m$ . In this model, the magnetic field at a distance  $r$  from the nucleus, perpendicular to the orbit, will be

- (a)  $\frac{Ze^3\mu_0}{16\pi^2\hbar\epsilon_0} \left(1 + \frac{r^2}{a^2}\right)^{-1/2}$
- (b)  $\frac{Ze^2\mu_0}{4\pi^2\hbar\epsilon_0} \frac{1}{a} \left(1 + \frac{r^2}{a^2}\right)^{-1/2}$
- (c)  $\frac{Ze\mu_0}{\hbar\epsilon_0} \left(1 + \frac{r^2}{a^2}\right)^{-3/2}$
- (d)  $\frac{Ze^3\mu_0}{8\pi\epsilon_0\hbar} \left(1 + \frac{r^2}{a^2}\right)^{-3/2}$

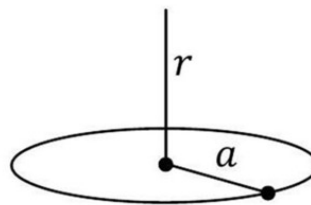

**Q16. [TIFR\_2019\_B\_Q7]**

Year 2019 · Electromagnetism · EM Waves · Only int. Phd · 5 marks

TIFR GS	2019	Section B
---------	------	-----------

A dielectric interface is formed by two homogeneous and isotropic dielectrics 1 and 2 with dielectric constants  $4/3$  and  $1$  respectively and it carries no residual free charge. A linearly polarized electromagnetic wave is incident on the interface from dielectric 1 at a point where the unit normal to the surface is  $\hat{n} = \frac{1}{2}(\sqrt{3}\hat{i} + \hat{k})$  pointing into the dielectric 1. The incident wave, which is incident from 1 into 2, just before it reaches the interface, has electric vector

$$\vec{E}_1 = \hat{i}E_0 \exp i\omega \left( t + \frac{\sqrt{\epsilon_1}}{c} z \right)$$

where  $E_0$  is a real constant. The electric vector just after it crosses the interface is rotated from  $\vec{E}_1$  by an angle

- (a)  $\pi/6$
- (b)  $\tan^{-1} \frac{2}{5\sqrt{3}}$
- (c)  $\sin^{-1} \frac{1}{2\sqrt{19}}$
- (d)  $\csc^{-1} 3\sqrt{\frac{4}{19}}$

**Q17. [TIFR\_2019\_C\_Q5]**

Year 2019 · Electromagnetism · EM Waves · Only PhD · 5 marks

TIFR GS	2019	Section C
---------	------	-----------

A monsoon cloud has a flat bottom of surface area  $125 \text{ km}^2$ . It floats horizontally over the ground at a level such that the base of the cloud is  $1.13 \text{ km}$  above the ground (see figure). Due to friction with the air below, the base of the cloud acquires a uniform electric charge density. This keeps increasing slowly with time. When the uniform electric field below the cloud reaches the value  $2.4 \text{ MVm}^{-1}$  a lightning discharge occurs, and the entire charge of the cloud passes to the Earth below - which, in this case, behaves like a grounded conductor. Neglecting edge effects and inhomogeneities inside the cloud and the air below, the energy released in this lightning discharge can be estimated, in kilowatt-hours (kWh), as about

- (a)  $10^9$
- (b)  $10^5$
- (c)  $10$
- (d)  $10^{-1}$

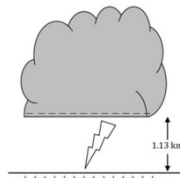

**Q18.** [TIFR\_2019\_C\_Q6]

Year 2019 · Electromagnetism · Potential Formulation · Only PhD · 5 marks

TIFR GS	2019	Section C
---------	------	-----------

The magnetic vector potential corresponding to a uniform magnetic field  $\vec{B}$  is often taken as

$$\vec{A} = \frac{1}{2} \vec{B} \times \vec{x}$$

This choice is

- (a) valid in the Lorenz gauge.
- (b) valid in the Coulomb gauge.
- (c) valid in the Weyl gauge.
- (d) gauge invariant.

**Electronics**

**Q19.** [TIFR\_2019\_A\_Q23]

Year 2019 · Electronics · Diodes · Both int. phd and phd · 3 marks

TIFR GS	2019	Section A
---------	------	-----------

The signal shown on the left side of the figure below is fed into the circuit shown on the right side.

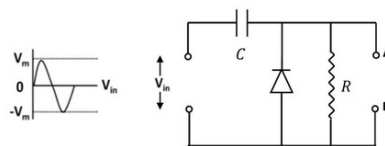

If the signal has time period  $\tau_S$  and the circuit has a natural frequency  $\tau_{RC}$ , then, in the case when  $\tau_S \ll \tau_{RC}$ , the steady-state output will resemble

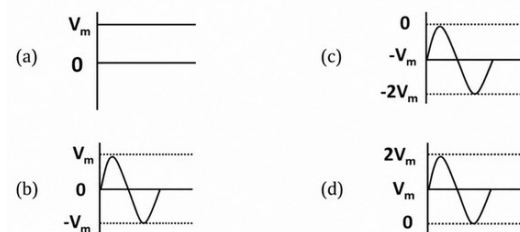

**Q20.** [TIFR\_2019\_A\_Q24]

Year 2019 · Electronics · Diodes · Both int. phd and phd · 3 marks

TIFR GS	2019	Section A
---------	------	-----------

Drawing power from a 12 V car battery, a 9 V stabilized DC voltage is required to power a car stereo system, attached to the terminals A and B, as shown in the figure.

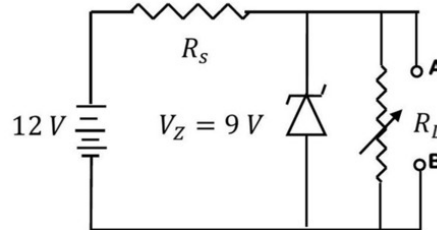

If a Zener diode with ratings,  $V_z = 9V$  and  $P_{max} = 0.27W$ , is connected as shown in the figure, for the above purpose, the minimum series resistance  $R_s$  must be

- (a) 111  $\Omega$
- (b) 103  $\Omega$
- (c) 100  $\Omega$
- (d) 97  $\Omega$

**Q21.** [TIFR\_2019\_A\_Q25]

Year 2019 · Electronics · Logic Gates · Both int. phd and phd · 3 marks

TIFR GS	2019	Section A
---------	------	-----------

The circuit shown below uses only NAND gates. The final output at C is

- (a) A AND B
- (b) A OR B
- (c) A XOR B
- (d) A NOR B

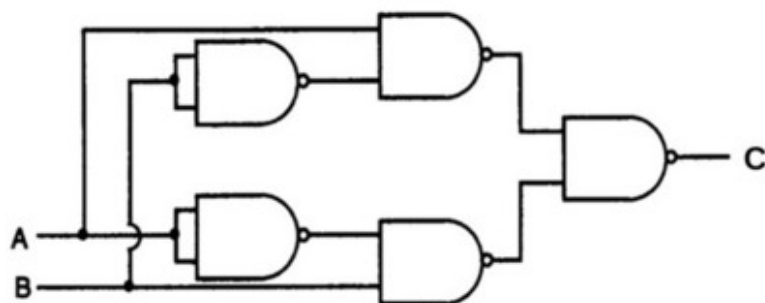

**Q22.** [TIFR\_2019\_C\_Q13]

Year 2019 · Electronics · OPAMP · Only PhD · 5 marks

TIFR GS	2019	Section C
---------	------	-----------

Consider the following circuit.

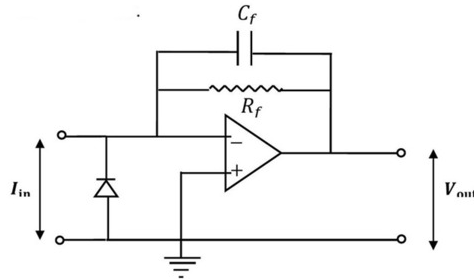

It is given that  $C_f = 100 \text{ pF}$ , and for  $I_{in} = 50 \text{ nA}$  D.C.,  $V_{out} = 1 \text{ V}$  D.C. Therefore, the bandwidth of the above circuit is

- (a) 15.8 Hz
- (b) 79.6 Hz
- (c) 145.3 Hz
- (d) 200.4 Hz

## Geometry

**Q23.** [TIFR\_2019\_A\_Q3]

Year 2019 · Geometry · Geometry · Both int. phd and phd · 3 marks

TIFR GS	2019	Section A
---------	------	-----------

Which of the following operations will transform a tetrahedron ABCD with vertices as listed below

	x	y	z
A	0	0	0
B	1	0	0
C	0	1	0
D	0	0	2

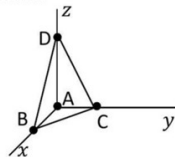

into a tetrahedron ABCD with vertices as listed below up to suitable translation?

	x	y	z
A	0	0	0
B	0	1	0
C	0	0	1
D	2	0	0

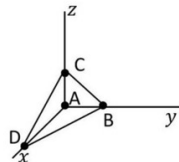

- (a) A rotation about x axis by  $\pi/2$ , then a rotation about z axis by  $\pi/2$
- (b) A reflection in the xy plane, then a rotation about x axis by  $\pi/2$
- (c) A reflection in the yz plane, then a reflection in the xy plane
- (d) A rotation about y axis by  $\pi/2$ , then a reflection in the xz plane

## Mathematical Physics

**Q24.** [TIFR\_2019\_A\_Q1]

Year 2019 · Mathematical Physics · Vector Analysis · Both int. phd and phd · 3 marks

TIFR GS	2019	Section A
---------	------	-----------

Consider the surface defined by  $ax^2 + by^2 + cz + d = 0$ , where  $a, b, c$  and  $d$  are constants. If  $\hat{n}_1$  and  $\hat{n}_2$  are unit normal vectors to the surface at the points  $(x, y, z) = (1, 1, 0)$  and  $(0, 0, 1)$  respectively, and  $\hat{m}$  is a unit vector normal to both  $\hat{n}_1$  and  $\hat{n}_2$ , then  $\hat{m} =$

- (a)  $\frac{-a\hat{i}+b\hat{j}}{\sqrt{a^2+b^2}}$   
 (b)  $\frac{b\hat{i}-a\hat{j}}{\sqrt{a^2+b^2}}$   
 (c)  $\frac{2a\hat{i}+2b\hat{j}-c\hat{k}}{\sqrt{4a^2+4b^2+c^2}}$   
 (d)  $\frac{a\hat{i}-b\hat{j}+c\hat{k}}{\sqrt{a^2+b^2+c^2}}$

**Q25.** [TIFR\_2019\_A\_Q2]

Year 2019 · Mathematical Physics · Matrices · Both int. phd and phd · 3 marks

TIFR GS	2019	Section A
---------	------	-----------

The eigenvalues of a  $3 \times 3$  matrix  $M$  are

$$\lambda_1 = 2 \quad \lambda_2 = -1 \quad \lambda_3 = 1$$

and the eigenvectors are

$$e_1 = \begin{pmatrix} 1 \\ 1 \\ 1 \end{pmatrix} \quad e_2 = \begin{pmatrix} 1 \\ 1 \\ -2 \end{pmatrix} \quad e_3 = \begin{pmatrix} 1 \\ -1 \\ 0 \end{pmatrix}$$

The matrix  $M$  is

- (a)  $\begin{pmatrix} 1 & 0 & 1 \\ 0 & 1 & 1 \\ 1 & 1 & 0 \end{pmatrix}$   
 (b)  $\begin{pmatrix} 0 & 1 & 1 \\ 1 & 0 & 0 \\ 1 & 0 & 2 \end{pmatrix}$   
 (c)  $\begin{pmatrix} 1 & 0 & 0 \\ 1 & 0 & -1 \\ 0 & -1 & 1 \end{pmatrix}$   
 (d)  $\begin{pmatrix} 1 & 1 & 0 \\ 1 & 0 & 1 \\ 0 & 1 & 1 \end{pmatrix}$

**Q26.** [TIFR\_2019\_A\_Q4]

Year 2019 · Mathematical Physics · Probability · Both int. phd and phd · 3 marks

TIFR GS	2019	Section A
---------	------	-----------

A British coin has a portrait of Queen Elizabeth II on the 'heads' side and 'ONE POUND' written on the 'tails' side, while an Indian coin has a portrait of Mahatma Gandhi on the 'heads' side and '10 RUPEES' written on the 'tails' side (see below).



These two coins are tossed simultaneously twice in succession. The result of the first toss was 'heads' for both the coins. The probability that the result of the second toss had a '10 RUPEES' side is

- (a)  $1/2$
- (b)  $4/7$
- (c)  $3/5$
- (d)  $2/3$

**Q27.** [TIFR\_2019\_A\_Q5]

Year 2019 · Mathematical Physics · Differential Equations · Both int. phd and phd · 3 marks

TIFR GS	2019	Section A
---------	------	-----------

A set of polynomials of order  $n$  are given by the formula

$$P_n(x) = (-1)^n \exp\left(\frac{x^2}{2}\right) \frac{d^n}{dx^n} \exp\left(-\frac{x^2}{2}\right)$$

The polynomial  $P_7(x)$  of order  $n = 7$  is

- (a)  $x^7 - 21x^5 + 105x^4 + 35x^3 - 105x$
- (b)  $x^6 - 21x^5 + 105x^4 - 105x^3 + 21x^2 + x$
- (c)  $x^7 - 21x^5 + 105x^3 - 105x + 21$
- (d)  $x^7 - 21x^5 + 105x^3 - 105x$

**Q28.** [TIFR\_2019\_B\_Q1]

Year 2019 · Mathematical Physics · Tensors · Only int. Phd · 5 marks

TIFR GS	2019	Section B
---------	------	-----------

An array  $\mathbb{T}$  has elements  $T_{ijkl}$  where  $i, j, k, l = 1, 2, 3, 4$ .  
It is given that

$$T_{ijkl} = T_{jikl} = T_{ijlk} = -T_{klij}$$

for all values of  $i, j, k, l$ . The number of independent components in this array is

- (a) 256
- (b) 55
- (c) 1
- (d) 45

**Q29.** [TIFR\_2019\_B\_Q2]

Year 2019 · Mathematical Physics · Differential Equations · Only int. Phd · 5 marks

TIFR GS	2019	Section B
---------	------	-----------

The differential equation

$$x \frac{dy}{dx} - xy = \exp(x)$$

where  $y = e^2$  at  $x = 1$ , has the solution  $y =$

- (a)  $\exp(x^2 + x)$
- (b)  $\exp(1 + x)(1 + \ln x)$
- (c)  $\exp(x)\ln x + \exp(1 + x)$
- (d)  $(1 - x)\exp(x) + \exp(1 + x)$

**Q30.** [TIFR\_2019\_C\_Q1]

Year 2019 · Mathematical Physics · Delta, Gamma, Beta and Integrals · Only PhD · 5 marks

TIFR GS	2019	Section C
---------	------	-----------

The integral

$$I = \int_0^{\infty} dx e^{-x} \delta(\sin x)$$

where  $\delta(x)$  denotes the Dirac delta function, is

- (a) 1
- (b)  $\frac{\exp \pi}{\exp \pi + 1}$
- (c)  $\frac{\exp \pi}{\exp \pi - 1}$
- (d)  $\frac{1}{\exp \pi - 1}$

**Q31.** [TIFR\_2019\_C\_Q2]

Year 2019 · Mathematical Physics · Complex Analysis · Only PhD · 5 marks

TIFR GS	2019	Section C
---------	------	-----------

Consider the complex function

$$f(x, y) = u(x, y) + iv(x, y)$$

where

$$u(x, y) = x^2(2 + x) - y^2(2 + 3x)$$

$$v(x, y) = y(\lambda x + 3x^2 - y^2)$$

and  $\lambda$  is real. If it is known that  $f(x, y)$  is analytic in the complex plane of  $z = x + iy$ , then it can be written

- (a)  $f = z^2(2 + z)$
- (b)  $f = \bar{z}(2 + \bar{z}^2)$
- (c)  $f = 2z\bar{z} + z^2 - \bar{z}^2$
- (d)  $f = z^2 + z^3$

**Modern Physics**

**Q32.** [TIFR\_2019\_A\_Q22]

Year 2019 · Modern Physics · Light Matter interaction · Both int. phd and phd · 3 marks

TIFR GS	2019	Section A
---------	------	-----------

The sketch shown below illustrates the apparatus and results for a famous experiment. The graph on the right is a polar plot of the number of electrons received in the detector.

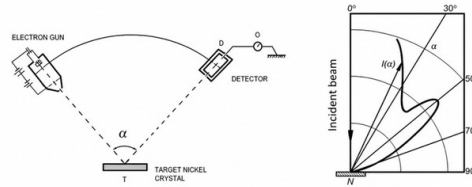

From the result, the experimenters were able to conclude that

- (a) the energy levels of atoms in a metal are quantized.
- (b) electrons in a beam can behave as waves.
- (c) electrons have spin half.
- (d) there are magnetic domains inside a nickel sample.

**Q33.** [TIFR\_2019\_B\_Q8]

Year 2019 · Modern Physics · Black Body Radiations · Only int. Phd · 5 marks

TIFR GS	2019	Section B
---------	------	-----------

In an experiment to measure the Earth's mean albedo (i.e. fraction of solar energy reflected back into space), the solar constant (i.e. flux of solar energy incident upon the Earth), was measured as  $1.37 \text{ kW m}^{-2}$ . Assuming the Earth to behave as a perfect blackbody at a uniform surface temperature of  $-18^\circ\text{C}$ , the albedo is about

- (a) 0.30
- (b) 0.18
- (c) 0.46
- (d) 0.06

**Nuclear and Particle Physics**

**Q34. [TIFR\_2019\_C\_Q14]**

Year 2019 · Nuclear and Particle Physics · Liquid Drop Model · Only PhD · 5 marks

TIFR GS	2019	Section C
---------	------	-----------

The semi-empirical mass formula for a heavy nucleon ( $Z, A$ ) can be written, to some approximation, as

$$M(Z, A)c^2 = ZM_p c^2 + (A - Z)M_n c^2 - \lambda_1 A - \lambda_2 A^{2/3} - \lambda_3 \frac{Z(Z-1)}{A^{1/3}} - \lambda_4 \frac{(A-2Z)^2}{A} - \frac{\lambda_5}{A^{1/2}}$$

where  $M_p c^2 = 938 \text{ MeV}$ ,  $M_n c^2 = 939 \text{ MeV}$ , and

$$\lambda_1 = 16, \lambda_2 = 18, \lambda_3 = 0.7, \lambda_4 = 23$$

all in MeV, where

$$\lambda_5 = \begin{cases} +12 & \text{MeV for even - even nuclei} \\ -12 & \text{MeV for odd - odd nuclei} \\ 0 & \text{for others} \end{cases}$$

Now, consider a spontaneous fission reaction

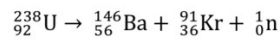

The energy released in this reaction will be close to

- (a) 17.92 keV
- (b) 19.2 MeV
- (c) 170 MeV
- (d) 190 MeV

**Q35. [TIFR\_2019\_C\_Q15]**

Year 2019 · Nuclear and Particle Physics · Particle Physics · Only PhD · 5 marks

TIFR GS	2019	Section C
---------	------	-----------

The table below gives the properties of four unstable particles  $\mu^+, \pi^+, n^0, \Lambda^0$

Particle	Mass (MeV/c <sup>2</sup> )	Spin	Principal decay mode
muon $\mu^+$	105.66	1/2	$\mu^+ \rightarrow e^+ + \nu_\mu + \bar{\nu}_e$
pion $\pi^+$	139.57	0	$\pi^+ \rightarrow \mu^+ + \nu_\mu$
neutron $n^0$	939.56	1/2	$n^0 \rightarrow p^+ + e^- + \bar{\nu}_e$
Lambda hyperon $\Lambda^0$	1,115.68	1/2	$\Lambda^0 \rightarrow p^+ + \pi^-$

If arranged in order of DECREASING decay lifetime, the above list will read

- (a)  $n^0, \mu^+, \pi^+, \Lambda^0$
- (b)  $\mu^+, \Lambda^0, n^0, \pi^+$
- (c)  $n^0, \Lambda^0, \mu^+, \pi^+$
- (d)  $\pi^+, n^0, \mu^+, \Lambda^0$

**Optics**

**Q36.** [TIFR\_2019\_B\_Q12]

Year 2019 · Optics · Diffraction · Only int. Phd · 5 marks

TIFR GS	2019	Section B
---------	------	-----------

The diffraction pattern due to a double slit experiment with two identical slits, is recorded in infra-red laser radiation of wavelength  $1.2 \mu\text{m}$  on a specially-prepared photographic plate at a distance of  $1.8 \text{ m}$  from the centre of the slits. A photograph of the observed diffraction pattern is given below. The distance between the slits can be calculated as

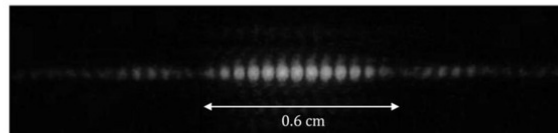

- (a)  $4.32 \text{ mm}$
- (b)  $5.04 \text{ mm}$
- (c)  $5.76 \text{ mm}$
- (d)  $9.36 \text{ mm}$

**Q37.** [TIFR\_2019\_B\_Q13]

Year 2019 · Optics · Interference · Only int. Phd · 5 marks

TIFR GS	2019	Section B
---------	------	-----------

In an experiment performed to determine the width of a thin transparent film of refractive index  $2.6$  deposited uniformly on the upper surface of a thick transparent glass block of refractive index  $1.5$ , a monochromatic laser beam of wavelength  $550 \text{ nm}$  was shone on the film at a variable angle  $\theta$  with the normal to the surface. If the intensity of the reflected beam was maximum when  $\theta = 5^\circ 24'$ , the thickness of the film may be inferred to be

- (a)  $13.2 \mu\text{m}$
- (b)  $2.92 \mu\text{m}$
- (c)  $1.12 \mu\text{m}$
- (d)  $0.48 \mu\text{m}$

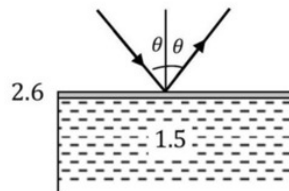

## Quantum Mechanics

**Q38.** [TIFR\_2019\_A\_Q19]

Year 2019 · Quantum Mechanics · Basic Quantum Mechanics · Both int. phd and phd · 3 marks

TIFR GS	2019	Section A
---------	------	-----------

A particle of mass  $m$ , moving in one dimension, satisfies the modified Schrödinger Equation

$$-\frac{\hbar^2}{2m} \frac{d^2\psi}{dx^2} + i\hbar u \frac{d\psi}{dx} = i\hbar \frac{d\psi}{dt}$$

where  $u$  is the velocity of the substrate. If, now, this particle is treated as a Gaussian wave packet peaked at wavenumber  $k$ , its group velocity will be  $v_g =$

- (a)  $\frac{\hbar k}{2m} - u$
- (b)  $\frac{\hbar k}{m} + u$
- (c)  $\frac{\hbar k}{m} - u$
- (d)  $-\frac{\hbar k}{2m} + u$

**Q39.** [TIFR\_2019\_A\_Q20]

Year 2019 · Quantum Mechanics · Basic Quantum Mechanics · Both int. phd and phd · 3 marks

TIFR GS	2019	Section A
---------	------	-----------

In a one-dimensional system, the boundary condition that the derivative of the wavefunction  $\psi'(x)$  should be continuous at every point is applicable whenever

- (a) the wavefunction  $\psi(x)$  is itself continuous everywhere.
- (b) there is a bound state and the potential is piecewise continuous.
- (c) there is a bound state and the potential has no singularity anywhere.
- (d) there are bound or scattering states with definite momentum.

**Q40.** [TIFR\_2019\_A\_Q21]

Year 2019 · Quantum Mechanics · Potential Well · Both int. phd and phd · 3 marks

TIFR GS	2019	Section A
---------	------	-----------

A particle moving in one dimension, is placed in an asymmetric square well potential  $V(x)$  as sketched below.

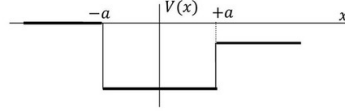

The probability density  $p(x)$  in the ground state will most closely resemble

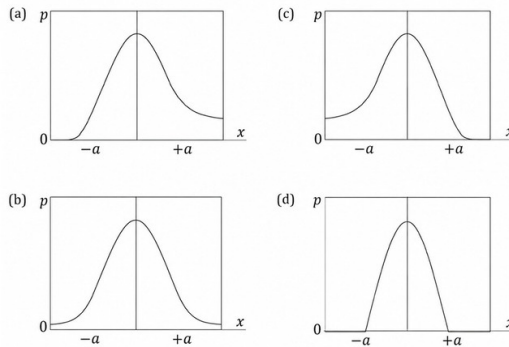
**Q41.** [TIFR\_2019\_B\_Q10]

Year 2019 · Quantum Mechanics · Potential Well · Only int. Phd · 5 marks

TIFR GS	2019	Section B
---------	------	-----------

An excited gas, consisting of spinless charged particles, is confined in an infinite square well potential of width  $a$ , is found to radiate a spectrum whose  $\alpha$  line (largest wavelength) has wavelength 816 nm . If the width  $a$  of the well is halved to  $a/2$ , the wavelength of the  $\delta$  line (fourth-largest wavelength) will be

- (a) 26.112  $\mu\text{m}$
- (b) 1.224  $\mu\text{m}$
- (c) 1.088  $\mu\text{m}$
- (d) 0.306  $\mu\text{m}$

**Q42.** [TIFR\_2019\_B\_Q11]

Year 2019 · Quantum Mechanics · Basic Quantum Mechanics · Only int. Phd · 5 marks

TIFR GS	2019	Section B
---------	------	-----------

The wavefunction of a non-relativistic particle of mass  $m$  in a one-dimensional potential  $V(x)$  has the form

$$\psi(x) = \sqrt{a}e^{-a|x|}$$

where  $|x|$  denotes the absolute value of the coordinate  $x$ . The potential is  $V(x) =$

- (a)  $-\frac{\hbar^2}{m} \delta\left(\frac{x}{a}\right)$
- (b)  $-\frac{\hbar^2 a}{m} \left\{a + \frac{1}{2} \delta(x)\right\}$
- (c)  $\frac{\hbar^2 a}{m} \delta(x)$
- (d) 0

**Q43.** [TIFR\_2019\_C\_Q10]

Year 2019 · Quantum Mechanics · Basic Quantum Mechanics · Only PhD · 5 marks

TIFR GS	2019	Section C
---------	------	-----------

A system of two spin- 1/2 particles 1 and 2 has the Hamiltonian

$$\hat{H} = \epsilon_0 \hat{h}_1 \otimes \hat{h}_2$$

where

$$\hat{h}_1 = \begin{pmatrix} 2 & 0 \\ 0 & 1 \end{pmatrix}, \hat{h}_2 = \begin{pmatrix} 0 & 1 \\ 1 & 0 \end{pmatrix}$$

and  $\epsilon_0$  is a constant with the dimension of energy.

The ground state of this system has energy

- (a)  $\sqrt{2}\epsilon_0$
- (b) 0
- (c)  $-2\epsilon_0$
- (d)  $-4\epsilon_0$

**Q44. [TIFR\_2019\_C\_Q11]**

Year 2019 · Quantum Mechanics · Basic Quantum Mechanics · Only PhD · 5 marks

TIFR GS	2019	Section C
---------	------	-----------

At time  $t = 0$ , the wavefunction of a particle in a harmonic oscillator potential of natural frequency  $\omega$  is given by

$$\psi(0) = \frac{1}{5} \{3\varphi_0 - 2\sqrt{2}\varphi_1 + 2\sqrt{2}\varphi_2\}$$

where  $\varphi_n(x)$  denotes the eigenfunction belonging to the  $n$ -th eigenvalue of energy. At time  $t = \tau$ , the wavefunction is found to be

$$\psi(\tau) = -\frac{i}{5} \{3\varphi_0 + 2\sqrt{2}\varphi_1 + 2\sqrt{2}\varphi_2\}$$

The minimum value of  $\tau$  is

- (a)  $\frac{\pi}{2\omega}$
- (b)  $\frac{2\pi}{\omega}$
- (c)  $\frac{2\pi}{3\omega}$
- (d)  $\frac{\pi}{\omega}$

**Q45. [TIFR\_2019\_C\_Q9]**

Year 2019 · Quantum Mechanics · Angular Momentum and Hydrogen atom · Only PhD · 5 marks

TIFR GS	2019	Section C
---------	------	-----------

An electron in a hydrogen atom is in a state described by the wavefunction:

$$\begin{aligned} \Psi(\vec{r}) &= \frac{1}{\sqrt{10}} \psi_{100}(\vec{x}) + \sqrt{\frac{2}{5}} \psi_{210}(\vec{x}) + \sqrt{\frac{2}{5}} \psi_{211}(\vec{x}) \\ &\quad - \frac{1}{\sqrt{10}} \psi_{21,-1}(\vec{x}) \end{aligned}$$

where  $\psi_{n\ell m}(\vec{x})$  denotes a normalized wavefunction of the hydrogen atom with the principal quantum number  $n$ , angular quantum number  $\ell$  and magnetic quantum number  $m$ .

Neglecting the spin-orbit interaction, the expectation values of  $\hat{L}_z$  and  $\hat{L}^2$  for this state are

- (a)  $3\hbar/10, 9\hbar^2/5$
- (b)  $3\hbar/5, 9\hbar^2/10$
- (c)  $3\hbar/4, 9\hbar^2/25$
- (d)  $8\hbar/10, 3\hbar^2/5$

**Solid State Physics**

**Q46.** [TIFR\_2019\_A\_Q18]

Year 2019 · Solid State Physics · XRay Diffraction · Both int. phd and phd · 3 marks

TIFR GS	2019	Section A
---------	------	-----------

A beam of high energy neutrons is scattered from a metal lattice, where the spacing between nuclei is around 0.4 nm . In order to see quantum diffraction effects, the kinetic energy of the neutrons must be around

- (a) 7.85 MeV
- (b) 5.11 meV
- (c) 511 keV
- (d) 78.5 eV

**Q47.** [TIFR\_2019\_B\_Q14]

Year 2019 · Solid State Physics · Semiconductor Physics · Only int. Phd · 5 marks

TIFR GS	2019	Section B
---------	------	-----------

In a sample of germanium, at a temperature 77 K , optical excitations create an average density of  $10^{12}$  conduction electrons per  $\text{cm}^3$  . At this temperature, the electron and hole mobilities are equal, and given by

$$\mu = 0.5 \times 10^4 \text{ cm}^2 \text{ s}^{-1} \text{ V}^{-1}$$

The value of the Einstein diffusion coefficient for the electrons and holes is

- (a)  $3.3 \times 10^{-2} \text{ m}^2 \text{ s}^{-1}$
- (b)  $1.65 \times 10^{-3} \text{ m}^2 \text{ s}^{-1}$
- (c)  $3.3 \times 10^{-3} \text{ m}^2 \text{ s}^{-1}$
- (d)  $6.6 \times 10^{-3} \text{ m}^2 \text{ s}^{-1}$

## Statistical Mechanics

**Q48.** [TIFR\_2019\_A\_Q16]

Year 2019 · Statistical Mechanics · Canonical Ensemble · Both int. phd and phd · 3 marks

TIFR GS	2019	Section A
---------	------	-----------

Consider a thermal ensemble at temperature  $T$  which is composed of identical quantum harmonic oscillators of frequency  $\omega_0$  with non-overlapping wavefunctions. The probability that there will be an even number of energy quanta in the system is

- (a)  $\frac{1}{\exp(-\hbar\omega_0/k_B T)+1}$   
 (b)  $\frac{1}{\exp(\hbar\omega_0/k_B T)+1}$   
 (c)  $\frac{1}{\exp(-\hbar\omega_0/k_B T)-1}$   
 (d)  $\tanh(\hbar\omega_0/2k_B T)$

**Q49.** [TIFR\_2019\_C\_Q12]

Year 2019 · Statistical Mechanics · Quantum Stat. Mech. · Only PhD · 5 marks

TIFR GS	2019	Section C
---------	------	-----------

At low temperatures, the measured specific heat  $C_V$  of a solid sample is found to depend on temperature as

$$C_V = aT^{3/2} + bT^3$$

where  $a$  and  $b$  are constants. This material has

- (a) one fermionic excitation with dispersion relation  $\omega \propto k^4$ ; another bosonic excitation with dispersion relation  $\omega \propto k$   
 (b) one fermionic excitation with dispersion relation  $\omega \propto k^2$ ; another bosonic excitation with dispersion relation  $\omega \propto k^4$   
 (c) one bosonic excitation with dispersion relation  $\omega \propto k^2$ ; another bosonic excitation with dispersion relation  $\omega \propto k$   
 (d) one fermionic excitation with dispersion relation  $\omega \propto k^2$ ; another fermionic excitation with dispersion relation  $\omega \propto k$

**Q50.** [TIFR\_2019\_C\_Q7]

Year 2019 · Statistical Mechanics · Quantum Stat. Mech. · Only PhD · 5 marks

TIFR GS	2019	Section C
---------	------	-----------

An ideal monatomic gas at chemical potential  $\mu = -1\text{eV}$  and a temperature given by  $k_B T = 0.1\text{eV}$  is in equilibrium with an adsorbing metal surface, i.e. there are isolated sites distributed randomly on the metal surface where the gas atom can get bound. Each such binding site can adsorb 0, 1, or 2 atoms with the released energy being 0,  $-1\text{eV}$  and  $-1.9\text{eV}$  respectively. The average number of adsorbed molecules at each site would be

- (a)  $\frac{1+e}{1-e}$   
 (b)  $\frac{1+e}{1+2e}$   
 (c)  $\frac{2+e}{1+2e}$   
 (d)  $\frac{1+2e}{1+e}$

**Thermodynamics****Q51.** [TIFR\_2019\_A\_Q14]

Year 2019 · Thermodynamics · Phase transition · Both int. phd and phd · 3 marks

TIFR GS	2019	Section A
---------	------	-----------

A thermally-insulated coffee mug contains 500 g of warm coffee at  $80^\circ\text{C}$ . Assuming that the heat capacity of this liquid is  $1\text{calg}^{-1}\text{ }^\circ\text{C}^{-1}$  and the latent heat of fusion for ice is  $80\text{calg}^{-1}$ , the amount of ice that must be dropped into the cup to convert it into cold coffee at  $5^\circ\text{C}$  is about

- (a) 421 g  
 (b) 441 g  
 (c) 469 g  
 (d) 471 g

**Q52.** [TIFR\_2019\_A\_Q15]

Year 2019 · Thermodynamics · Laws of thermodynamics · Both int. phd and phd · 3 marks

TIFR GS	2019	Section A
---------	------	-----------

An ideal gas engine is run according to the cycle shown in the  $s - T$  diagram below, where the process from D to A is known to be isochoric (i.e. maintaining  $V = \text{constant}$ ).

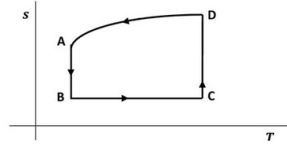

The corresponding cycle in the  $p - V$  diagram will most closely resemble

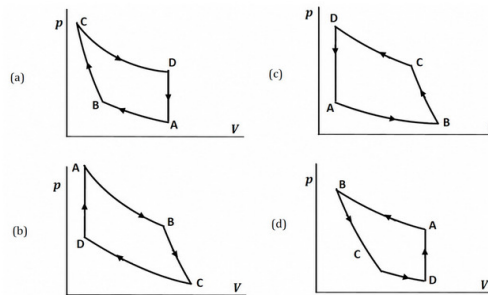

**Q53.** [TIFR\_2019\_A\_Q17]

Year 2019 · Thermodynamics · Kinetic Theory of Gases · Both int. phd and phd · 3 marks

TIFR GS	2019	Section A
---------	------	-----------

Consider the following linear model of a molecule of hydrogen cyanide (HCN) depicted below. It follows that the molar specific heat of hydrogen cyanide gas at constant pressure must be

- (a)  $6 R$
- (b)  $4.5 R$
- (c)  $5 R$
- (d)  $5.5 R$

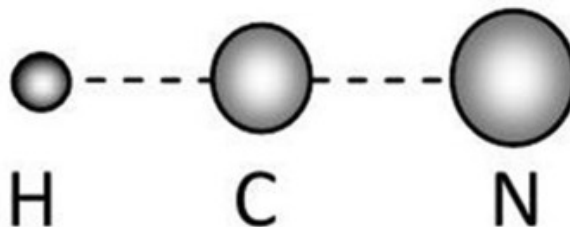

**Q54. [TIFR\_2019\_B\_Q9]**

Year 2019 · Thermodynamics · Laws of thermodynamics · Only int. Phd · 5 marks

TIFR GS	2019	Section B
---------	------	-----------

The molar equation of state of a gas at temperature  $T$ , pressure  $P$  and volume  $V$  is given by

$$P = \frac{RT}{V - b} - \frac{a}{TV^2}$$

where,  $a$  and  $b$  are two constants and  $R$  is the gas constant. The critical temperature and pressure for this gas will be

(a)  $T_c = \sqrt{\frac{a}{27Rb}}$ ,  $P_c = \frac{RT_c}{b}$

(b)  $T_c = \sqrt{\frac{8a}{27Rb}}$ ,  $P_c = \frac{RT_c}{8b}$

(c)  $T_c = \sqrt{\frac{4a}{27Rb}}$ ,  $P_c = \frac{RT_c}{4b}$

(d)  $T_c = \sqrt{\frac{8a}{3Rb}}$ ,  $P_c = \frac{RT_c}{8b}$

**Q55. [TIFR\_2019\_C\_Q8]**

Year 2019 · Thermodynamics · Laws of thermodynamics · Only PhD · 5 marks

TIFR GS	2019	Section C
---------	------	-----------

Consider  $N$  non-interacting distinguishable particles in equilibrium at an absolute temperature  $T$ . Each particle can only occupy one of two possible states of energy  $0$  and  $\epsilon$  respectively ( $\epsilon > 0$ ). The entropy of the system, in terms of  $\beta = \epsilon/k_B T$  is

(a)  $Nk_B \left\{ \ln(1 + e^{-\beta}) - \frac{e^{-\beta}}{1 + e^{-\beta}} \right\}$

(b)  $Nk_B \left\{ \ln(1 + e^{-\beta}) + \frac{\beta e^{-\beta}}{1 + e^{-\beta}} \right\}$

(c)  $Nk_B \left\{ \ln(1 - e^{-\beta}) + \frac{\beta e^{-\beta}}{1 - e^{-\beta}} \right\}$

(d)  $Nk_B \left\{ \ln(1 + e^{-\beta}) - \frac{e^{-\beta}}{1 - e^{-\beta}} \right\}$

# Answer Key & Index

Complete TIFR GS Physics Paper · 2019 · 55 questions

#	Question ID	Subject	Topic	Ans	Marks
1	TIFR_2019_A_Q6	Classical Mechanics	Basic Mechanics	c	3
2	TIFR_2019_A_Q7	Classical Mechanics	Oscillations	d	3
3	TIFR_2019_A_Q8	Classical Mechanics	Basic Mechanics	d	3
4	TIFR_2019_A_Q9	Classical Mechanics	Rotational Motion	d	3
5	TIFR_2019_B_Q3	Classical Mechanics	Lagrangian and Hamiltonian	a	5
6	TIFR_2019_B_Q4	Classical Mechanics	Oscillations	d	5
7	TIFR_2019_B_Q5	Classical Mechanics	Special Theory of Relativity	a	5
8	TIFR_2019_C_Q3	Classical Mechanics	Lagrangian and Hamiltonian	d	5
9	TIFR_2019_C_Q4	Classical Mechanics	Special Theory of Relativity	b	5
10	TIFR_2019_A_Q10	Electromagnetism	Magnetostatics	a	3
11	TIFR_2019_A_Q11	Electromagnetism	Electric Field in matter	b	3
12	TIFR_2019_A_Q12	Electromagnetism	Electrodynamics	c	3
13	TIFR_2019_A_Q13	Electromagnetism	EM Waves	c	3
14	TIFR_2019_B_Q15	Electromagnetism	Electrostatics	d	5
15	TIFR_2019_B_Q6	Electromagnetism	Magnetostatics	d	5
16	TIFR_2019_B_Q7	Electromagnetism	EM Waves	c	5
17	TIFR_2019_C_Q5	Electromagnetism	EM Waves	a	5
18	TIFR_2019_C_Q6	Electromagnetism	Potential Formulation	b	5
19	TIFR_2019_A_Q23	Electronics	Diodes	d	3
20	TIFR_2019_A_Q24	Electronics	Diodes	c	3
21	TIFR_2019_A_Q25	Electronics	Logic Gates	c	3
22	TIFR_2019_C_Q13	Electronics	OPAMP	b	5
23	TIFR_2019_A_Q3	Geometry	Geometry	a	3
24	TIFR_2019_A_Q1	Mathematical Physics	Vector Analysis	b	3
25	TIFR_2019_A_Q2	Mathematical Physics	Matrices	a	3
26	TIFR_2019_A_Q4	Mathematical Physics	Probability	b	3
27	TIFR_2019_A_Q5	Mathematical Physics	Differential Equations	d	3
28	TIFR_2019_B_Q1	Mathematical Physics	Tensors	d	5
29	TIFR_2019_B_Q2	Mathematical Physics	Differential Equations	c	5
30	TIFR_2019_C_Q1	Mathematical Physics	Delta, Gamma, Beta and Integra	c	5
31	TIFR_2019_C_Q2	Mathematical Physics	Complex Analysis	a	5
32	TIFR_2019_A_Q22	Modern Physics	Light Matter interaction	b	3
33	TIFR_2019_B_Q8	Modern Physics	Black Body Radiations	a	5
34	TIFR_2019_C_Q14	Nuclear and Particle Physics	Liquid Drop Model	d	5
35	TIFR_2019_C_Q15	Nuclear and Particle Physics	Particle Physics	a	5
36	TIFR_2019_B_Q12	Optics	Diffraction	b	5

#	Question ID	Subject	Topic	Ans	Marks
37	TIFR_2019_B_Q13	Optics	Interference	c	5
38	TIFR_2019_A_Q19	Quantum Mechanics	Basic Quantum Mechanics	c	3
39	TIFR_2019_A_Q20	Quantum Mechanics	Basic Quantum Mechanics	c	3
40	TIFR_2019_A_Q21	Quantum Mechanics	Potential Well	a	3
41	TIFR_2019_B_Q10	Quantum Mechanics	Potential Well	b	5
42	TIFR_2019_B_Q11	Quantum Mechanics	Basic Quantum Mechanics	a	5
43	TIFR_2019_C_Q10	Quantum Mechanics	Basic Quantum Mechanics	c	5
44	TIFR_2019_C_Q11	Quantum Mechanics	Basic Quantum Mechanics	d	5
45	TIFR_2019_C_Q9	Quantum Mechanics	Angular Momentum and Hydrogen	a	5
46	TIFR_2019_A_Q18	Solid State Physics	XRay Diffraction	b	3
47	TIFR_2019_B_Q14	Solid State Physics	Semiconductor Physics	c	5
48	TIFR_2019_A_Q16	Statistical Mechanics	Canonical Ensemble	a	3
49	TIFR_2019_C_Q12	Statistical Mechanics	Quantum Stat. Mech.	c	5
50	TIFR_2019_C_Q7	Statistical Mechanics	Quantum Stat. Mech.	c	5
51	TIFR_2019_A_Q14	Thermodynamics	Phase transition	b	3
52	TIFR_2019_A_Q15	Thermodynamics	Laws of thermodynamics	a	3
53	TIFR_2019_A_Q17	Thermodynamics	Kinetic Theory of Gases	d	3
54	TIFR_2019_B_Q9	Thermodynamics	Laws of thermodynamics	b	5
55	TIFR_2019_C_Q8	Thermodynamics	Laws of thermodynamics	b	5

Practice these questions in test mode at [physicspyq.com](http://physicspyq.com) · Join Aaryan Sir's full TIFR Physics course at [physicsbyaaryan.com](http://physicsbyaaryan.com)