



PhysicsByAaryan

TIFR Physics 2020

Complete TIFR GS Physics Paper · 2020 · 55 questions
Visit: physicsbyaaryan.com · physicspyq.com

Atomic and Molecular Physics

Q1. [TIFR_2020_A_Q20]

Year 2020 · Atomic and Molecular Physics · Bohr model · Both int. phd and phd · 3 marks

TIFR GS	2020	Section A
---------	------	-----------

A sample of hydrogen gas was placed in a discharge tube and its spectrum was measured using a high-resolution spectrometer. The H_{α} line in the spectrum was found to be split into two lines, a high intensity line at 656.28 nm, and a low intensity line at 656.01 nm. This indicates that the hydrogen sample was contaminated with

- (a) deuterium
- (b) tritium
- (c) helium
- (d) water vapour

Classical Mechanics

Q2. [TIFR_2020_A_Q6]

Year 2020 · Classical Mechanics · Central Forces, Gravitation and Universe · Both int. phd and phd · 3 marks

TIFR GS	2020	Section A
---------	------	-----------

Consider a satellite orbiting the Earth in a circular orbit, as sketched in the figure given below (not to scale). The satellite has four small thruster rockets, whose exhaust gases come out along

- (A) the forward direction,
 - (B) the backward direction,
 - (C) radially inward towards the Earth's centre, and
 - (D) radially outward from the Earth's centre,
- as indicated in the figure.

If the satellite wants to increase its speed, while remaining in a circular orbit, and has fuel enough to keep only one thruster rocket in operation, it should fire the rocket marked

- (a) A
- (b) B
- (c) C
- (d) D

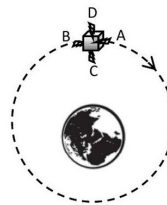

Q3. [TIFR_2020_A_Q7]

Year 2020 · Classical Mechanics · Oscillations · Both int. phd and phd · 3 marks

TIFR GS	2020	Section A
---------	------	-----------

A particle of mass m hangs from a light spring inside a lift (see figure). When the lift is at rest, the mass oscillates in the vertical direction with an angular frequency 2.5rad/s . Now consider the following situation.

The suspended mass is at rest inside the lift which is descending vertically at a speed of 0.5 m/s . If the lift suddenly stops, the amplitude of oscillations of the mass will be

- (a) 0.20 m
- (b) 0.25 m
- (c) 0.05 m
- (d) 1.25 m

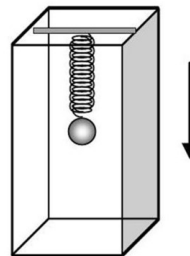

Q4. [TIFR_2020_A_Q8]

Year 2020 · Classical Mechanics · Central Forces, Gravitation and Universe · Both int. phd and phd · 3 marks

TIFR GS	2020	Section A
---------	------	-----------

Consider two planets P_1 and P_2 which can be modeled as uniform spheres of radii R_1 and R_2 respectively, and of the same material with the same density and other physical properties. If the maximum possible height of a conical mountain (of the same material) on these planets is denoted by h_1 and h_2 respectively ($h_1 \ll R_1$, $h_2 \ll R_2$), then the ratio h_1/h_2 is

- (a) R_2/R_1
- (b) R_1/R_2
- (c) $R_2^{2/3}/R_1^{2/3}$
- (d) $R_1^{2/3}/R_2^{2/3}$

Q5. [TIFR_2020_A_Q9]

Year 2020 · Classical Mechanics · Special Theory of Relativity · Both int. phd and phd · 3 marks

TIFR GS	2020	Section A
---------	------	-----------

A particle of rest mass $\sqrt{3}$ g emerges from a gun with a velocity $v = c/4$. If the rest mass of the gun is 1 kg, its approximate speed of recoil will be

- (a) $c/1000$
- (b) $c/2236$
- (c) $c/1732$
- (d) $c/2309$

Q6. [TIFR_2020_B_Q3]

Year 2020 · Classical Mechanics · Rotational Motion · Only int. Phd · 5 marks

TIFR GS	2020	Section B
---------	------	-----------

A roundabout whose rotating base is a heavy uniform disc of radius 2 m and mass 400 kg has a central pillar and handles which are of negligible mass (see figure). The roundabout is set rotating at a steady rate of 20 r.p.m.

Four small children, of mass 10 kg, 20 kg, 30 kg and 40 kg respectively, step gently on to the edge of the roundabout, each with velocity 7.2 km/hr along a tangential direction and cling to the handles. After holding on for some time, the children step gently off the roundabout with the same velocity, but this time in a radial direction.

Neglecting all effects of friction and air drag, the final rate of rotation of the roundabout will be about

- (a) 28 r.p.m.
- (b) 25 r.p.m.
- (c) 36 r.p.m.
- (d) 21 r.p.m.

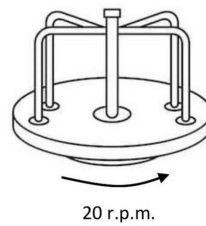

Q7. [TIFR_2020_B_Q4]

Year 2020 · Classical Mechanics · Special Theory of Relativity · Only int. Phd · 5 marks

TIFR GS	2020	Section B
---------	------	-----------

In the laboratory frame, a particle at rest starts moving with a speed $c/2$ from one corner of a square (see figure) and traverses the four sides of the square so that it returns to its original position. At each corner, it changes direction without any change in speed.

If the entire square now moves with a speed $c/3$ in the laboratory frame, as indicated in the figure, the speed of the particle (in the laboratory frame) when it returns to its original position will be

- (a) $\frac{2\sqrt{2}c}{15}$
- (b) $\frac{c}{5}$
- (c) $\frac{2\sqrt{2}c}{3}$
- (d) $\frac{c}{5\sqrt{3}}$

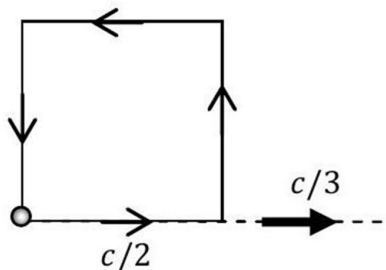

Q8. [TIFR_2020_C_Q3]

Year 2020 · Classical Mechanics · Oscillations · Only PhD · 5 marks

TIFR GS	2020	Section C
---------	------	-----------

A uniform rod of length ℓ and mass m is suspended horizontally from a rigid support by two identical massless springs, each with stiffness constant k , as sketched below. If the springs can move only in the vertical direction, the frequency of small oscillations of the rod about equilibrium is given by

- (a) $\sqrt{2k/m}$ and $\sqrt{6k/m}$
 (b) $\sqrt{2k/m}$ and $\sqrt{2\pi k/m}$
 (c) $\sqrt{\pi k/2m}$ and $\sqrt{6k/m}$
 (d) $\sqrt{k/m}$ and $\sqrt{2\pi k/m}$

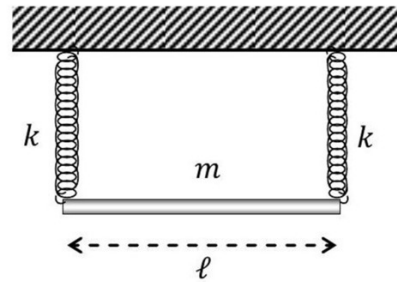
**Q9. [TIFR_2020_C_Q4]**

Year 2020 · Classical Mechanics · Lagrangian and Hamiltonian · Only PhD · 5 marks

TIFR GS	2020	Section C
---------	------	-----------

The Lagrangian of a system described by generalised coordinates q_1 and q_2 is given by

$$L = \frac{a}{2} (\dot{q}_1^2 + \dot{q}_2^2) - \frac{b^2}{\pi} (q_1^2 + q_2^2)$$

where a and b are constants.

It follows that a conserved quantity in this system is

- (a) $q_1 \dot{q}_2 - q_2 \dot{q}_1$
 (b) $q_1 \dot{q}_2 + q_2 \dot{q}_1$
 (c) $\frac{q_1 \dot{q}_2 - q_2 \dot{q}_1}{q_1^2 + q_2^2}$
 (d) $2\pi(q_1^2 \dot{q}_2 + q_2^2 \dot{q}_1)$

Electromagnetism

Q10. [TIFR_2020_A_Q10]

Year 2020 · Electromagnetism · Electrostatics · Both int. phd and phd · 3 marks

TIFR GS	2020	Section A
---------	------	-----------

Consider two concentric spheres of radii a and b , where $a < b$ (see figure). The (shaded) space between the two spheres is filled uniformly with total charge Q . The electric field at any point between the two spheres at distance r from the centre is given by

- (a) $\frac{Q}{4\pi\epsilon_0} \frac{r^3 - a^3}{r^2(b^3 - a^3)}$
 (b) $\frac{Q}{4\pi\epsilon_0} \frac{1}{r^2}$
 (c) $\frac{Q}{4\pi\epsilon_0} \left(\frac{b}{r^4} - \frac{a}{r^4} \right)^{2/3}$
 (d) zero

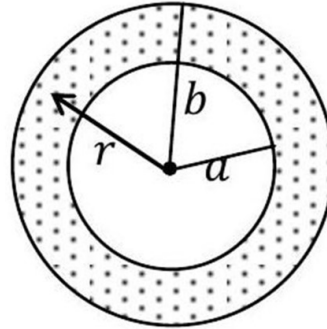
**Q11.** [TIFR_2020_A_Q11]

Year 2020 · Electromagnetism · Magnetostatics · Both int. phd and phd · 3 marks

TIFR GS	2020	Section A
---------	------	-----------

A metallic wire of uniform cross-section and resistance R is bent into a circle of radius a . The circular loop is placed in a magnetic field $\vec{B}(t)$ which is perpendicular to the plane of the wire. This magnetic field is uniform over space, but its magnitude decreases with time at a constant rate k , where

$$k = -\frac{d|\vec{B}(t)|}{dt}$$

The tension in the metallic wire is

- (a) $\frac{\pi a^3 k}{2R} |\vec{B}(t)|$
 (b) $\frac{\pi a^3 k}{R} |\vec{B}(t)|$
 (c) $\frac{2\pi a^3 k}{R} |\vec{B}(t)|$
 (d) zero

Q12. [TIFR_2020_A_Q12]

Year 2020 · Electromagnetism · Magnetostatics · Both int. phd and phd · 3 marks

TIFR GS	2020	Section A
---------	------	-----------

Four students were asked to write down possible forms for the magnetic vector potential $\vec{A}(\vec{x})$ corresponding to a uniform magnetic field of magnitude B along the positive z direction. Three returned correct answers and one returned an incorrect answers. Their answers are reproduced below. Which was the incorrect answer?

- (a) $Bx\hat{j}$
 (b) $-By\hat{i}$
 (c) $\frac{1}{2}(Bx\hat{i} - By\hat{j})$
 (d) $\frac{1}{2}(-By\hat{i} + Bx\hat{j})$

Q13. [TIFR_2020_A_Q13]

Year 2020 · Electromagnetism · EM Waves · Both int. phd and phd · 3 marks

TIFR GS	2020	Section A
---------	------	-----------

The components of the electric and magnetic fields corresponding to a plane electromagnetic field propagating in vacuum satisfy

$$E_x = E_y = -E_z = \frac{|\vec{E}|}{\sqrt{3}},$$

$$B_x = -B_y = \frac{|\vec{B}|}{\sqrt{2}},$$

$$B_z = 0$$

A unit vector along the direction of propagation of the plane wave is

- (a) $\frac{\hat{i} + \hat{j} + 2\hat{k}}{\sqrt{6}}$
 (b) $-\frac{\hat{i} + \hat{j} + 2\hat{k}}{\sqrt{6}}$
 (c) $\frac{2\hat{i} - 2\hat{j} + \hat{k}}{\sqrt{3}}$
 (d) $-\frac{2\hat{i} - 2\hat{j} + \hat{k}}{\sqrt{3}}$

Q14. [TIFR_2020_B_Q1]

Year 2020 · Electromagnetism · Electrostatics · Only int. Phd · 5 marks

TIFR GS	2020	Section B
---------	------	-----------

A two-dimensional electrostatic field is defined as

$$\vec{E}(x, y) = -x\hat{i} + y\hat{j}$$

A correct diagram for the lines of force is

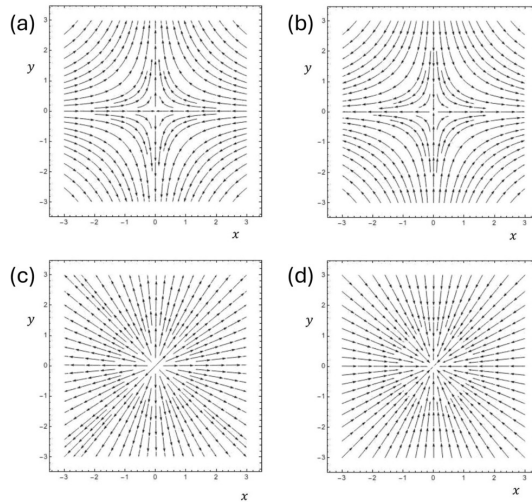

Q15. [TIFR_2020_B_Q5]

Year 2020 · Electromagnetism · Image Problems · Only int. Phd · 5 marks

TIFR GS	2020	Section B
---------	------	-----------

A light rigid insulating rod of length ℓ is suspended horizontally from a rigid frictionless pivot at one of the ends (see figure). At a vertical distance h below the rod there is an infinite plane conducting plane, which is grounded.

If two small, light spherical conductors are attached at the ends of the rod and given charges $+Q$ and $-Q$ as indicated in the figure, the torque on the rod will be

- (a) $\frac{Q^2}{4\pi\epsilon_0\ell} \hat{k}$
- (b) $-\frac{Q^2}{4\pi\epsilon_0\ell} \hat{k}$
- (c) $\frac{(4-\sqrt{2}) Q^2}{16\pi\epsilon_0 \ell} \hat{k}$
- (d) $-\frac{(4-\sqrt{2}) Q^2}{16\pi\epsilon_0 \ell} \hat{k}$

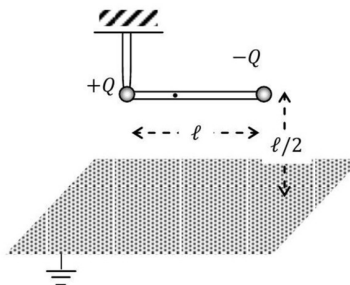

Q16. [TIFR_2020_B_Q6]

Year 2020 · Electromagnetism · Magnetostatics · Only int. Phd · 5 marks

TIFR GS	2020	Section B
---------	------	-----------

The magnetic vector potential $\vec{A} \equiv A_x \hat{i} + A_y \hat{j} + A_z \hat{k}$ is defined in a region R of space by

$$\begin{aligned} A_x &= 5 \cos \pi y \\ A_y &= 2 + \sin \pi x \\ A_z &= 0 \end{aligned}$$

in an appropriate unit.

If L be a square loop of wire in the $x - y$ plane, with its ends at

$$(0, 0) \quad (0, 0.25) \quad (0.25, 0.25) \quad (0.25, 0)$$

in an appropriate unit and it lies entirely in the region R, the numerical value of the flux of the above magnetic field (in the same units) passing through L is

- (a) 0.543
- (b) 3.31
- (c) -0.75
- (d) zero

Q17. [TIFR_2020_C_Q5]

Year 2020 · Electromagnetism · Electrostatics · Only PhD · 5 marks

TIFR GS	2020	Section C
---------	------	-----------

Two conducting uncharged spheres of radii R_1 and R_2 are connected by an infinitesimally thin wire. The centres of the spheres are located at \vec{r}_1 and \vec{r}_2 respectively with respect to the origin O . The system is subjected to an uniform external electric field \vec{E}_0 .

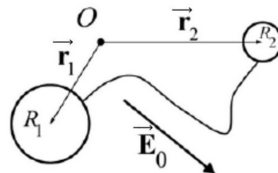

If the wire cannot support a net charge and the two spheres are separated by distance much larger than the radii of each of them, the induced dipole moment in the system would be

- (a) $4\pi\epsilon_0 \frac{R_1 R_2}{R_1 + R_2} \left\{ \vec{E}_0 \cdot (\vec{r}_2 - \vec{r}_1) \right\} (\vec{r}_2 - \vec{r}_1)$
- (b) $\frac{1}{4\pi\epsilon_0} \frac{R_1 R_2}{(R_1 + R_2)} \left\{ \vec{E}_0 \cdot (\vec{r}_2 - \vec{r}_1) \right\} (\vec{r}_2 - \vec{r}_1)$
- (c) $4\pi\epsilon_0 \frac{R_1 + R_2}{R_1 R_2} \left\{ \vec{E}_0 \cdot (\vec{r}_2 - \vec{r}_1) \right\} (\vec{r}_2 - \vec{r}_1)$
- (d) zero

Q18. [TIFR_2020_C_Q6]

Year 2020 · Electromagnetism · EM Waves · Only PhD · 5 marks

TIFR GS	2020	Section C
---------	------	-----------

Consider the following situation.

An infinite plane metallic plate of thickness 1.8 cm is placed along the $x - y$ plane, with the z axis normal to the sheet (see figure).

A plane radio wave of intensity I_0 and frequency 29.5 MHz propagates in vacuum along the negative z -axis and strikes the metal foil at normal incidence.

If the metal of the foil has conductivity $5.9\Omega^{-1} \text{ m}^{-1}$ and magnetic permeability $\mu \approx 1$, the intensity I_E of the emergent wave will be approximately

- (a) $0.26 I_0$
- (b) $0.51 I_0$
- (c) $0.29 \times 10^{-7} I_0$
- (d) $2.08 \times 10^{-4} I_0$

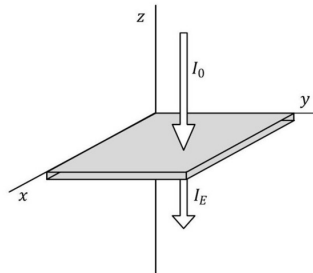

Electronics

Q19. [TIFR_2020_A_Q22]

Year 2020 · Electronics · OPAMP · Both int. phd and phd · 3 marks

TIFR GS	2020	Section A
---------	------	-----------

In the above circuit, which of the following is the maximum value, in Volts, of voltage at V_{out} ?

- (a) 10
- (b) 15
- (c) 0
- (d) 5

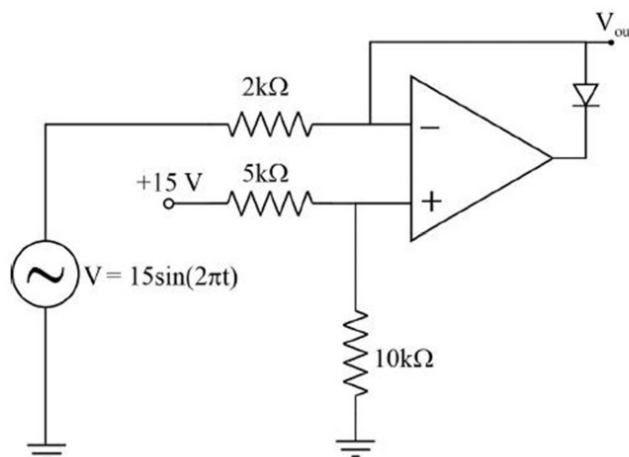

Q20. [TIFR_2020_A_Q24]

Year 2020 · Electronics · Logic Gates · Both int. phd and phd · 3 marks

TIFR GS	2020	Section A
---------	------	-----------

An OR gate, a NOR gate and an XOR gate are to be constructed using only NAND gates.

If the minimum number of NAND gates needed to construct OR, NOR and XOR gates is denoted $n(\text{OR})$, $n(\text{NOR})$ and $n(\text{XOR})$ respectively, then

- (a) $n(\text{NOR}) = n(\text{XOR}) > n(\text{OR})$
- (b) $n(\text{NOR}) = n(\text{XOR}) = n(\text{OR})$
- (c) $n(\text{NOR}) > n(\text{XOR}) > n(\text{OR})$
- (d) $n(\text{NOR}) < n(\text{XOR}) = n(\text{OR})$

Q21. [TIFR_2020_B_Q11]

Year 2020 · Electronics · Transistors · Only int. Phd · 5 marks

TIFR GS	2020	Section B
---------	------	-----------

The circuit shown below represents a typical voltage-divider bias circuit for a transistor. Assume that resistance values and voltage values are typical for using the transistor as an amplifier.

Which of the following changes in the circuit would result in an increase in the collector voltage V_C ?

- (a) R_2 is decreased slightly
- (b) R_2 is increased slightly
- (c) R_C is decreased slightly
- (d) R_C is increased slightly

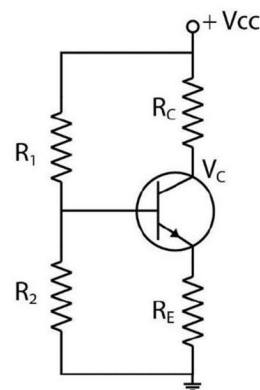

Q22. [TIFR_2020_C_Q11]

Year 2020 · Electronics · OPAMP · Only PhD · 5 marks

TIFR GS	2020	Section C
---------	------	-----------

The circuit sketched below is called a relaxation oscillator.

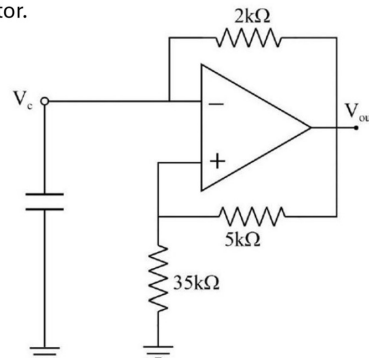

For the parameters indicated in the figure, the ratio of the maximum voltage at V_{out} to the maximum voltage at V_c is

- (a) 1/8
- (b) 1/7
- (c) 2/7
- (d) 1/4

Experimental Physics

Q23. [TIFR_2020_A_Q17]

Year 2020 · Experimental Physics · Data Analysis · Both int. phd and phd · 3 marks

TIFR GS	2020	Section A
---------	------	-----------

Four students are asked to draw on the same semi-logarithmic plot the energy distributions $f(E)$ of a classical gas (with a solid line), a boson gas (with a dashed line) and a fermion gas (with a dash-dot line) respectively, each as a function of energy E . Only one student's answer was correct. The graphs submitted by the four students are given below. The correct one is

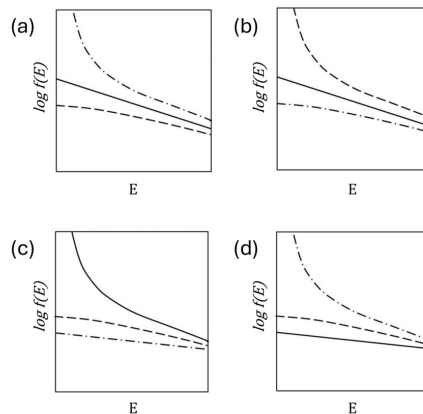

Q24. [TIFR_2020_A_Q23]

Year 2020 · Experimental Physics · Instruments · Both int. phd and phd · 3 marks

TIFR GS	2020	Section A
---------	------	-----------

A badly-designed voltmeter is modeled as an ideal voltmeter with a large resistor (R) and a large capacitor (C) connected in parallel to it. Given this information, which of the following statements describes what happens when this voltmeter is connected to a DC voltage source with voltage V and internal resistance r ($r \ll R$) ?

- (a) The reading on the voltmeter rises slowly and becomes steady at a value slightly less than V .
- (b) The reading on the voltmeter starts at a value slightly less than V and slowly falls to zero.
- (c) The reading on the voltmeter rises slowly to a maximum value close to V and then slowly goes to zero.
- (d) The reading on the voltmeter reads zero even when connected to the voltage source.

Q25. [TIFR_2020_A_Q25]

Year 2020 · Experimental Physics · Instruments · Both int. phd and phd · 3 marks

TIFR GS	2020	Section A
---------	------	-----------

On passing electric current, a tungsten filament is emitting electrons by thermionic emission. In order to maintain the energy of the electron beam obtained from this source at a value approximately 100 eV, which of the following methods will work in practice?

- (a) Float the filament at -100 Volts with a grounded aperture in front of it.
- (b) Heat the filament so that the emitted electrons will have 100 eV kinetic energy due to temperature.
- (c) Apply a +100 Volts potential with respect to the filament potential to an aperture kept very close to the filament.
- (d) Use an appropriate magnetic field to draw out the electron beam at the desired energy without applying any electric field.

Geometry

Q26. [TIFR_2020_A_Q1]

Year 2020 · Geometry · Geometry · Both int. phd and phd · 3 marks

TIFR GS	2020	Section A
---------	------	-----------

A three-dimensional view of a solid is sketched below.

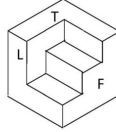

The three projections below are each intended to show the solid from its front (F), left side (L) and top (T), as marked in the figure. Which one is correct?

- (a)
- (b)
- (c)
- (d)

Mathematical Physics

Q27. [TIFR_2020_A_Q2]

Year 2020 · Mathematical Physics · Limits, Continuity and Differentiation · Both int. phd and phd · 3 marks

TIFR GS	2020	Section A
---------	------	-----------

The limit

$$\lim_{x \rightarrow \infty} x \log \frac{x+1}{x-1}$$

evaluates to

- (a) 2
- (b) 0
- (c) ∞
- (d) 1

Q28. [TIFR_2020_A_Q3]

Year 2020 · Mathematical Physics · Matrices · Both int. phd and phd · 3 marks

TIFR GS	2020	Section A
---------	------	-----------

The eigenvector e_1 corresponding to the smallest eigenvalue of the matrix

$$\begin{pmatrix} 2a^2 & a & 0 \\ a & 1 & a \\ 0 & a & 2a^2 \end{pmatrix}$$

where $a = \sqrt{\frac{3}{2}}$, is given (in terms of its transpose) by

(a) $e_1^T = \frac{1}{2} \left(\frac{1}{\sqrt{2}} \quad -\sqrt{3} \quad \frac{1}{\sqrt{2}} \right)$

(b) $e_1^T = \frac{1}{2} \left(\sqrt{\frac{3}{2}} \quad 1 \quad \sqrt{\frac{3}{2}} \right)$

(c) $e_1^T = \frac{1}{\sqrt{2}} (1 \quad 0 \quad -1)$

(d) $e_1^T = \frac{1}{\sqrt{2}} (1 \quad 0 \quad 1)$

Q29. [TIFR_2020_A_Q4]

Year 2020 · Mathematical Physics · Differential Equations · Both int. phd and phd · 3 marks

TIFR GS	2020	Section A
---------	------	-----------

Consider the improper differential

$$ds = (1 + y^2)dx + xydy$$

An integrating factor for this is

(a) $-x$

(b) $1 + x^2$

(c) xy

(d) $-1 + y^2$

Q30. [TIFR_2020_B_Q2]

Year 2020 · Mathematical Physics · Limits, Continuity and Differentiation · Only int. Phd · 5 marks

TIFR GS	2020	Section B
---------	------	-----------

The sum of the infinite series

$$S = 1 + \frac{3}{5} + \frac{6}{25} + \frac{10}{125} + \frac{15}{625} + \dots$$

is given by

(a) $S = \frac{125}{64}$

(b) $S = \frac{25}{16}$

(c) $S = \frac{25}{24}$

(d) $S = \frac{16}{25}$

Q31. [TIFR_2020_C_Q1]

Year 2020 · Mathematical Physics · Differential Equations · Only PhD · 5 marks

TIFR GS	2020	Section C
---------	------	-----------

The solution of the differential equation

$$\frac{dy}{dx} = 1 + \frac{y}{x} - \frac{y^2}{x^2}$$

for $x > 0$ with the boundary condition $y = 0$ at $x = 1$.is given by $y(x) =$

(a) $\frac{x(x^2-1)}{x^2+1}$

(b) $\frac{x(x-1)}{x+1}$

(c) $\frac{x-1}{x+1}$

(d) $\frac{x^2-1}{x^2+1}$

Q32. [TIFR_2020_C_Q12]

Year 2020 · Mathematical Physics · Fourier and Laplace Analysis · Only PhD · 5 marks

TIFR GS	2020	Section C
---------	------	-----------

The figure below shows a carrier frequency 4 kHz being amplitude-modulated by a sine wave signal. In order to transmit the signal (without distortion) the minimum bandwidth needed would be

- (a) 8 kHz
- (b) 2 kHz
- (c) 4 kHz
- (d) 6 kHz

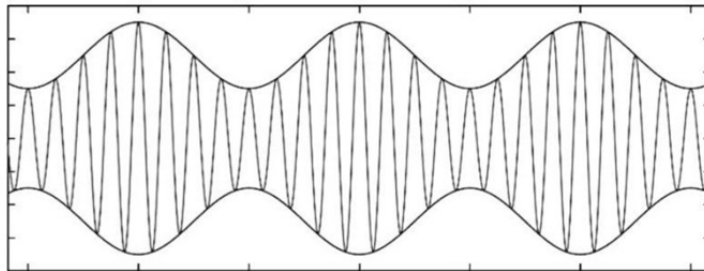

Q33. [TIFR_2020_C_Q2]

Year 2020 · Mathematical Physics · Complex Analysis · Only PhD · 5 marks

TIFR GS	2020	Section C
---------	------	-----------

The value of the integral

$$\int_0^{\infty} \frac{dx}{x^4 + 4}$$

Is

- (a) $\frac{\pi}{8}$
- (b) $\frac{3\pi}{8}$
- (c) 2π
- (d) $\frac{\pi}{4}$

Nuclear and Particle Physics

Q34. [TIFR_2020_B_Q13]

Year 2020 · Nuclear and Particle Physics · Radioactivity · Only int. Phd · 5 marks

TIFR GS	2020	Section B
---------	------	-----------

Consider the nuclear decay chain of radio-Bismuth to Polonium to Lead, i.e.

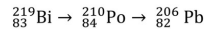

where Pb – 206 (${}_{82}^{206}\text{Pb}$) is a stable nucleus, and Bi-210 (${}_{83}^{210}\text{Bi}$) and Po-206 (${}_{84}^{210}\text{Po}$) are radioactive nuclei with half lives of about 5 days and 138 days respectively.

If we start with a sample of pure Bi-210 (${}_{83}^{210}\text{Bi}$), then a possible graph for the time evolution of the number of nuclei of these three species will be

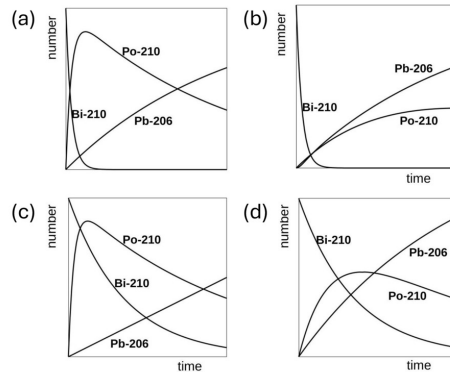

Q35. [TIFR_2020_C_Q10]

Year 2020 · Nuclear and Particle Physics · Radioactivity · Only PhD · 5 marks

TIFR GS	2020	Section C
---------	------	-----------

A spin-2 nucleus absorbs a spin- 1/2 electron and is then observed to decay to a stable nucleus in two stages, recoiling against an emitted invisible particle in the first stage and against an emitted spin-1 photon in the second stage. If the stable nucleus is spinless, then the spin of the invisible particle is

- (a) 3/2 or 5/2
- (b) 3/2
- (c) 1/2 or 3/2
- (d) 1/2

Q36. [TIFR_2020_C_Q14]

Year 2020 · Nuclear and Particle Physics · Radioactivity · Only PhD · 5 marks

TIFR GS	2020	Section C
---------	------	-----------

Two atomic nuclei A and B have masses such that $m(B) = 2m(A)$. in the laboratory frame, the nucleus B is kept stationary, while the nucleus A is given a kinetic energy 300 MeV and made to collide with B. It is found that the two nuclei fuse to form a compound nucleus C .

If the Q -value of the reaction is -30 MeV , the excitation energy of the compound nucleus can be estimated as

- (a) 81 MeV
- (b) 170 MeV
- (c) 330 MeV
- (d) 270 MeV

Q37. [TIFR_2020_C_Q15]

Year 2020 · Nuclear and Particle Physics · Particle Physics · Only PhD · 5 marks

TIFR GS	2020	Section C
---------	------	-----------

Which of the following decays is forbidden?

- (a) $\pi^0 \rightarrow \gamma + \gamma$
- (b) $K^0 \rightarrow \pi^+ + \pi^- + \pi^0$
- (c) $\mu^- \rightarrow e^- + \nu_e + \bar{\nu}_\mu$
- (d) $n^0 \rightarrow p^+ + e^- + \bar{\nu}_e$

Optics

Q38. [TIFR_2020_B_Q14]

Year 2020 · Optics · Interference · Only int. Phd · 5 marks

TIFR GS	2020	Section B
---------	------	-----------

A monochromatic laser beam is incident on a wet piece of filter paper atop a sheet of glass of thickness d . The pattern observed on the paper is

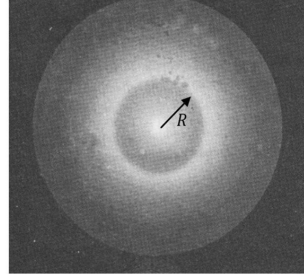

If the radius of the inner ring observed is R , the refractive index of the glass must be

- (a) $\sin \left\{ \tan^{-1} \left(\frac{R}{2d} \right) \right\}$
- (b) $\sin \left\{ \tan^{-1} \left(\frac{R}{d} \right) \right\}$
- (c) $\tan \left\{ \sin^{-1} \left(\frac{R}{2d} \right) \right\}$
- (d) $\tan \left\{ \sin^{-1} \left(\frac{R}{d} \right) \right\}$

Q39. [TIFR_2020_B_Q15]

Year 2020 · Optics · Polarization · Only int. Phd · 5 marks

TIFR GS	2020	Section B
---------	------	-----------

A plane polarised light wave with electric field expressed as

$$\vec{E}(z, t) = E_0 \hat{j} \cos(kz - \omega t)$$

is incident from the left on the apparatus as sketched below.

The apparatus consists of (from left to right) a polariser with transmission axis at $\pi/4$ w.r.t. the y -axis, followed by a quarter-wave plate with fast axis along the y -axis, and finally, a polariser with transmission axis at $\pi/3$ about the x -axis.

If the incident intensity of the wave is I_0 , What will be the intensity of the light emerging out of the apparatus (on the right)?

- (a) $I_0/4$
- (b) $I_0/8$
- (c) $3I_0/8$
- (d) $I_0/16$

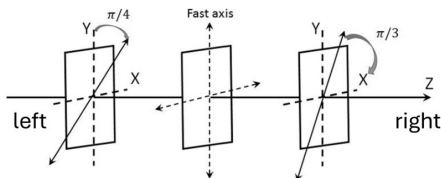

Quantum Mechanics

Q40. [TIFR_2020_A_Q18]

Year 2020 · Quantum Mechanics · Angular Momentum and Hydrogen atom · Both int. phd and phd · 3 marks

TIFR GS	2020	Section A
---------	------	-----------

The wave function of a particle subjected to a three-dimensional spherically-symmetric potential $V(r)$ is given by

$$\psi(\vec{x}) = (x + y + 3z)f(r)$$

The expectation value for the operator \vec{L}^2 for this state is

- (a) \hbar^2
- (b) $2\hbar^2$
- (c) $5\hbar^2$
- (d) $11\hbar^2$

Q41. [TIFR_2020_A_Q19]

Year 2020 · Quantum Mechanics · Potential Well · Both int. phd and phd · 3 marks

TIFR GS	2020	Section A
---------	------	-----------

A fermion of mass m , moving in two dimensions, is strictly confined inside a square box of side ℓ . The potential inside is zero. A measurement of the energy of the fermion yields the result

$$E = \frac{65\pi^2\hbar^2}{2m\ell^2}$$

The degeneracy of this energy state is

- (a) 2
- (b) 4
- (c) 8
- (d) 16

Q42. [TIFR_2020_A_Q21]

Year 2020 · Quantum Mechanics · Basic Quantum Mechanics · Both int. phd and phd · 3 marks

TIFR GS	2020	Section A
---------	------	-----------

The momentum operator

$$i\hbar \frac{d}{dx}$$

acts on a wavefunction $\psi(x)$. This operator is Hermitian

- (a) provided the wavefunction $\psi(x)$ is normalized
- (b) provided the wavefunction $\psi(x)$ and derivate $\psi'(x)$ are continuous everywhere
- (c) provided the wavefunction $\psi(x)$ vanishes as $x \rightarrow \pm\infty$
- (d) by its very definition

Q43. [TIFR_2020_B_Q10]

Year 2020 · Quantum Mechanics · quantum Harmonic Oscillator · Only int. Phd · 5 marks

TIFR GS	2020	Section B
---------	------	-----------

Three noninteracting particles whose masses are in the ratio 1:4:16 are placed together in the same harmonic oscillator potential $V(x)$.

The degeneracies of the first three energy eigenstates (ordered by increasing energy) will be

- (a) 1,1,1
- (b) 1, 1, 2
- (c) 1,2,1
- (d) 1,2,2

Q44. [TIFR_2020_B_Q9]

Year 2020 · Quantum Mechanics · Perturbation theory · Only int. Phd · 5 marks

TIFR GS	2020	Section B
---------	------	-----------

A particle of mass m is confined inside a box with boundaries at $x = \pm L$. The ground state and the first excited state of this particle are E_1 and E_2 respectively. Now a repulsive delta function potential $\lambda\delta(x)$ is introduced at the centre of the box where the constant λ satisfies

$$0 < \lambda \ll \frac{1}{32m} \left(\frac{\hbar}{L}\right)^2$$

If the energies of the new ground state and the new first excited state be denoted as E'_1 and E'_2 respectively, it follows that

- (a) $E'_1 > E_1, E'_2 > E_2$
- (b) $E'_1 = E_1, E'_2 = E_2$
- (c) $E'_1 > E_1, E'_2 = E_2$
- (d) $E'_1 = E_1, E'_2 > E_2$

Q45. [TIFR_2020_C_Q9]

Year 2020 · Quantum Mechanics · Basic Quantum Mechanics · Only PhD · 5 marks

TIFR GS	2020	Section C
---------	------	-----------

A particle of mass m is placed in a one-dimensional harmonic oscillator potential

$$V(x) = \frac{1}{2} m\omega^2 x^2$$

At $t = 0$, its wavefunction is $\psi(x)$. At $t = 2\pi/\omega$ its wavefunction will be

- (a) $\psi(x)$
- (b) $-\psi(x)$
- (c) $-\pi\psi(x)$
- (d) $\frac{2\pi}{\omega}\psi(x)$

Solid State Physics

Q46. [TIFR_2020_B_Q12]

Year 2020 · Solid State Physics · XRay Diffraction · Only int. Phd · 5 marks

TIFR GS	2020	Section B
---------	------	-----------

A beam of X-rays is incident upon a powder sample of a material which forms simple cubic crystals of lattice constant 5.5\AA . The maximum wavelength of the X-rays which can produce diffraction from the planes with Miller indices $(0,0,5)$ is

- (a) 2.2\AA
- (b) 55.0\AA
- (c) 1.1\AA
- (d) 27.5\AA

Q47. [TIFR_2020_C_Q13]

Year 2020 · Solid State Physics · Semiconductor Physics · Only PhD · 5 marks

TIFR GS	2020	Section C
---------	------	-----------

A semiconductor with donor impurities can be thought in terms of a filled valence band, a filled donor level and an empty valence band at $T = 0$, as shown in the figure below.

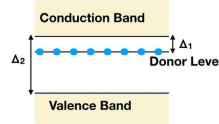

If the band gap between donor level and conduction band is Δ_1 and that between conduction and valence band is Δ_2 where $\Delta_2 \gg \Delta_1$, which of the following figures depict the qualitative features of the resistance (R)-vs-temperature (T) graph of the semi-conductor?

(Assume temperature-independent scattering rates and a flat density of states for the bands.)

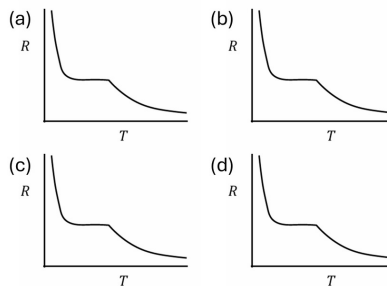

Statistical Mechanics

Q48. [TIFR_2020_A_Q14]

Year 2020 · Statistical Mechanics · Microcanonical Ensemble · Both int. phd and phd · 3 marks

TIFR GS	2020	Section A
---------	------	-----------

A gas has the following equation of state

$$U = \frac{aS^5}{N^2V^2}$$

where U is the internal energy, V is the volume and N is the number of particles. Here a is a constant of the appropriate dimension. It follows that the equation of state of this gas relating its pressure P to its temperature T and its density $\rho = N/V$ is given by

- (a) $\frac{P^4}{T^5\rho^2} = \text{constant}$
 (b) $\frac{P^5}{T^4\rho^3} = \text{constant}$
 (c) $\frac{P}{T\rho} = \text{constant}$
 (d) $\frac{P^3}{T^2\rho^3} = \text{constant}$

Q49. [TIFR_2020_B_Q8]

Year 2020 · Statistical Mechanics · Canonical Ensemble · Only int. Phd · 5 marks

TIFR GS	2020	Section B
---------	------	-----------

A system is composed of a large number of non-interacting classical particles moving in two dimensions, which individually obey the Hamiltonian

$$\frac{p_x^2 + p_y^2}{2m} + \frac{1}{2}m\omega^2(x^2 + y^2)$$

and the system is connected to a heat bath at a temperature T . The probability of finding a particle within a radius R from the origin is given by

- (a) $1 - \exp\left(-\frac{m\omega^2 R^2}{2T}\right)$
 (b) $\exp\left(-\frac{m\omega^2 R^2}{2T}\right)$
 (c) $\text{erf}\left(\sqrt{\frac{m}{2T}}\omega R\right)$
 (d) $1 - \frac{m\omega^2 R^2}{2T}$

Q50. [TIFR_2020_C_Q7]

Year 2020 · Statistical Mechanics · Canonical Ensemble · Only PhD · 5 marks

TIFR GS	2020	Section C
---------	------	-----------

In a certain atom, the ground state and first excited state of the valence electron are -7.8 eV and -3.9 eV, while all the higher excited states have energies very close to zero. The ground state has a degeneracy of 2, while the first excited state has a degeneracy of 6.

It follows that if these atoms reside in the outer layers of a blue giant star at a temperature around 2.32×10^4 K, the average energy per atom will be approximately

- (a) -5.1 eV
- (b) -5.9 eV
- (c) -6.8 eV
- (d) -4.4 eV

Q51. [TIFR_2020_C_Q8]

Year 2020 · Statistical Mechanics · Microstates · Only PhD · 5 marks

TIFR GS	2020	Section C
---------	------	-----------

A square lattice consists of $2N$ sites, of which alternate sites are labeled A and B. An example with $N = 6$ is shown on the right. Now, N identical classical particles are distributed over these sites, such that each site can accommodate at most one particle.

A	B	A	B	A	B
B	A	B	A	B	A
A	B	A	B	A	B
B	A	B	A	B	A
A	B	A	B	A	B
B	A	B	A	B	A

The fraction of the total number N of particles occupying A sites is denoted α and the fraction occupying B sites is denoted β , so that $\alpha + \beta = 1$.

If α, β are fixed and $N \gg 1$, the entropy S of the system can be written

- (a) $S = -2Nk_B T(\alpha \ln \alpha + \beta \ln \beta)$
- (b) $S = 2Nk_B T(\alpha \ln \alpha + \beta \ln \beta)$
- (c) $S = -2Nk_B T(\alpha \ln \alpha - \beta \ln \beta)$
- (d) $S = 2Nk_B T(\alpha \ln \alpha - \beta \ln \beta)$

Thermodynamics

Q52. [TIFR_2020_A_Q15]

Year 2020 · Thermodynamics · Carnot Cycle · Both int. phd and phd · 3 marks

TIFR GS	2020	Section A
---------	------	-----------

An ideal gas is passed through a cyclic process where the corresponding changes in the thermodynamic potentials are plotted on the adjoining graph. Here U is the internal energy and F is the Helmholtz free energy.

The efficiency of this cycle is given by

- (a) $1 - \frac{U_1}{U_2}$
 (b) $1 - \exp\left(-\frac{F_2}{F_1}\right)$
 (c) $1 - \frac{U_1}{U_2} \exp\left(-\frac{F_2}{F_1}\right)$
 (d) $\exp\left(\frac{U_1}{U_2}\right) - \exp\left(-\frac{F_2}{F_1}\right)$

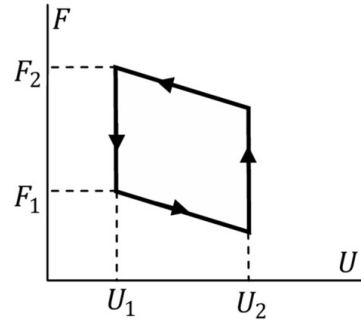
**Q53.** [TIFR_2020_A_Q16]

Year 2020 · Thermodynamics · Kinetic Theory of Gases · Both int. phd and phd · 3 marks

TIFR GS	2020	Section A
---------	------	-----------

The mean free path λ of molecules of a gas at room temperatures is given approximately by

$$\lambda = \frac{1}{n\sigma}$$

where n is the number density of the molecules and σ is the collision cross-section of two molecules. It follows that the mean free path of air molecules at normal temperature and pressure is of order

- (a) $500\mu\text{ m}$
 (b) 50 nm
 (c) 0.5 nm
 (d) 500 fm

Q54. [TIFR_2020_A_Q5]

Year 2020 · Thermodynamics · Kinetic Theory of Gases · Both int. phd and phd · 3 marks

TIFR GS	2020	Section A
---------	------	-----------

Consider a sphere of radius R , with the north pole N marked as shown in the figure below.

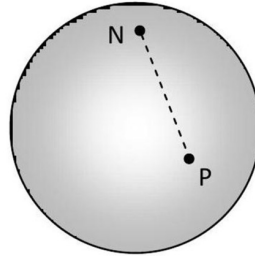

The r.m.s. distance (straight line cutting through the sphere) of a point P on the sphere from this north pole N is given by

- (a) R
- (b) $2\sqrt{2/5}R$
- (c) $\sqrt{4\pi}R$
- (d) $\sqrt{2}R$

Q55. [TIFR_2020_B_Q7]

Year 2020 · Thermodynamics · Laws of thermodynamics · Only int. Phd · 5 marks

TIFR GS	2020	Section B
---------	------	-----------

The volume V of a rectangular box is divided into two equal parts by a solid non-permeable partition P. On one side of the partition P there is a vacuum, while the other side is filled with a real gas having equation of state

$$pVe^{a/RTV} = nRT$$

where a and b are constants, The gas was initially at a uniform temperature T_0 . Then the partition P was removed instantaneously, and the gas was allowed to expand to fill the full volume of the box and come to equilibrium.

The final temperature of the gas, in terms of its specific heat C_v will be

- (a) $T - \left(\frac{na}{C_v}\right) \ln 2$
- (b) $T + \left(\frac{na}{C_v}\right) \ln 2$
- (c) $T - 2n \left(\frac{RTa}{C_v}\right)^{3/2}$
- (d) $T + 2n \left(\frac{RTa}{C_v}\right)^{3/2}$

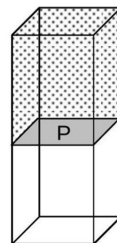

Answer Key & Index

Complete TIFR GS Physics Paper · 2020 · 55 questions

#	Question ID	Subject	Topic	Ans	Marks
1	TIFR_2020_A_Q20	Atomic and Molecular Physics	Bohar model	c	3
2	TIFR_2020_A_Q6	Classical Mechanics	Central Forces, Gravitation an	d	3
3	TIFR_2020_A_Q7	Classical Mechanics	Oscillations	a	3
4	TIFR_2020_A_Q8	Classical Mechanics	Central Forces, Gravitation an	a	3
5	TIFR_2020_A_Q9	Classical Mechanics	Special Theory of Relativity	b	3
6	TIFR_2020_B_Q3	Classical Mechanics	Rotational Motion	b	5
7	TIFR_2020_B_Q4	Classical Mechanics	Special Theory of Relativity	a	5
8	TIFR_2020_C_Q3	Classical Mechanics	Oscillations	a	5
9	TIFR_2020_C_Q4	Classical Mechanics	Lagrangian and Hamiltonian	a	5
10	TIFR_2020_A_Q10	Electromagnetism	Electrostatics	a	3
11	TIFR_2020_A_Q11	Electromagnetism	Magnetostatics	a	3
12	TIFR_2020_A_Q12	Electromagnetism	Magnetostatics	d	3
13	TIFR_2020_A_Q13	Electromagnetism	EM Waves	b	3
14	TIFR_2020_B_Q1	Electromagnetism	Electrostatics	a	5
15	TIFR_2020_B_Q5	Electromagnetism	Image Problems	d	5
16	TIFR_2020_B_Q6	Electromagnetism	Magnetostatics	a	5
17	TIFR_2020_C_Q5	Electromagnetism	Electrostatics	c	5
18	TIFR_2020_C_Q6	Electromagnetism	EM Waves	a	5
19	TIFR_2020_A_Q22	Electronics	OPAMP	a	3
20	TIFR_2020_A_Q24	Electronics	Logic Gates	a	3
21	TIFR_2020_B_Q11	Electronics	Transistors	a	5
22	TIFR_2020_C_Q11	Electronics	OPAMP	a	5
23	TIFR_2020_A_Q17	Experimental Physics	Data Anaysis	a	3
24	TIFR_2020_A_Q23	Experimental Physics	Instruments	a	3
25	TIFR_2020_A_Q25	Experimental Physics	Instruments	a	3
26	TIFR_2020_A_Q1	Geometry	Geometry	a	3
27	TIFR_2020_A_Q2	Mathematical Physics	Limits, Continuity and Differe	a	3
28	TIFR_2020_A_Q3	Mathematical Physics	Matrices	a	3
29	TIFR_2020_A_Q4	Mathematical Physics	Differential Equations	a	3
30	TIFR_2020_B_Q2	Mathematical Physics	Limits, Continuity and Differe	a	5
31	TIFR_2020_C_Q1	Mathematical Physics	Differential Equations	a	5
32	TIFR_2020_C_Q12	Mathematical Physics	Fourier and Laplace Analysis	b	5
33	TIFR_2020_C_Q2	Mathematical Physics	Complex Analysis	a	5
34	TIFR_2020_B_Q13	Nuclear and Particle Physics	Radioactivity	a	5
35	TIFR_2020_C_Q10	Nuclear and Particle Physics	Radioactivity	a	5
36	TIFR_2020_C_Q14	Nuclear and Particle Physics	Radioactivity	b	5

#	Question ID	Subject	Topic	Ans	Marks
37	TIFR_2020_C_Q15	Nuclear and Particle Physics	Particle Physics	c	5
38	TIFR_2020_B_Q14	Optics	Interference	a	5
39	TIFR_2020_B_Q15	Optics	Polarization	a	5
40	TIFR_2020_A_Q18	Quantum Mechanics	Angular Momentum and Hydrogen	b	3
41	TIFR_2020_A_Q19	Quantum Mechanics	Potential Well	c	3
42	TIFR_2020_A_Q21	Quantum Mechanics	Basic Quantum Mechanics	c	3
43	TIFR_2020_B_Q10	Quantum Mechanics	quantum Harmonic Oscillator	b	5
44	TIFR_2020_B_Q9	Quantum Mechanics	Perturbation theory	c	5
45	TIFR_2020_C_Q9	Quantum Mechanics	Basic Quantum Mechanics	b	5
46	TIFR_2020_B_Q12	Solid State Physics	XRay Diffraction	a	5
47	TIFR_2020_C_Q13	Solid State Physics	Semiconductor Physics	a	5
48	TIFR_2020_A_Q14	Statistical Mechanics	Microcanonical Ensemble	a	3
49	TIFR_2020_B_Q8	Statistical Mechanics	Canonical Ensemble	a	5
50	TIFR_2020_C_Q7	Statistical Mechanics	Canonical Ensemble	c	5
51	TIFR_2020_C_Q8	Statistical Mechanics	Microstates	a	5
52	TIFR_2020_A_Q15	Thermodynamics	Carnot Cycle	a	3
53	TIFR_2020_A_Q16	Thermodynamics	Kinetic Theory of Gases	b	3
54	TIFR_2020_A_Q5	Thermodynamics	Kinetic Theory of Gases	d	3
55	TIFR_2020_B_Q7	Thermodynamics	Laws of thermodynamics	a	5

Practice these questions in test mode at [physicspyq.com](https://www.physicspyq.com) · Join Aaryan Sir's full TIFR Physics course at [physicsbyaaryan.com](https://www.physicsbyaaryan.com)